

The background of the entire page is a light gray line-art map of a city street grid. A prominent location pin icon is centered on the map, pointing downwards. The text is overlaid on this background.

xplova X5 Evo

Smart Video Cycling Computer
User Manual

xplova

CONTENTS

Safety Laws and Regulations	1	Delete a training plan	28
Important Safety Instructions	3	Route	29
Welcome	6	Download a route	29
Warning	6	Start a route	29
Download apps	6	Stop a route	29
Meet your X5 Evo	7	Delete a route	29
Package contents	7	ANT+ Sensors	30
Getting to know your X5 Evo	8	Heart Rate Monitor	30
Setting Up	9	Combo Sensors	30
Charging X5 Evo to 100%	9	Shimano Di2	31
Installing X5 Evo on the bike	9	App Tutorial	32
Turning on X5 Evo	9	Xplova Connect	32
Performing the initial setup	9	How to pair/unpair devices	32
Home screen overview	11	Route Planning	33
Status bar icon	11	Activity	34
Cycling with X5 Evo	12	Training	35
Preparations	12	Settings	35
Start a free ride	13	Xplova Video	36
Page introduction	14	How to pair devices	36
Dashboard	14	Play a video	37
Map page	15	Crop a video	37
Data and Chart pages	15	Edit a video	37
Quick Access Menu	16	Share a video	38
Data field customization	16	Delete a video	38
Alert settings	18	Side menu settings	38
Activity settings	18	General Settings	40
Auto Lap	18	Profile	40
Auto Pause	19	Bike mode	40
Map download	19	Bike	40
Download maps	19	Device	40
Delete maps	20	My Map	40
Activities	21	Record Settings	40
View activity	21	ANT+ sensors	40
Delete activity	21	Network	40
Challenge mode	21	System	40
Unfinished activity	22	GPS	40
Upload activity	22	Display	40
Video	23	Hibernate	41
Choose record mode	23	Sounds	41
Setup record mode	23	Time	41
Mute recording	25	Units	42
View video	25	Language	42
Delete video	25	Clear User Data	42
Record preview mode	26	About	42
Upload video	26	Appendix	43
Training	27	Descriptions of customized data	
Start a training plan	27	fields	43
Stop a training plan	28	Specifications	47
		Declaration of Conformity	48

SAFETY LAWS AND REGULATIONS

Laws and Regulations Information Governing Wireless Internet Card

Use the Unit on Aircraft

Warning: FCC and FAA regulations prohibit radio-frequency wireless devices (including wireless network cards) from operating in the air because their wireless signals can cause serious interference to flight equipment.

The wireless network card included in this Unit, like any other radio devices, emits radio frequency electromagnetic waves. However, a wireless network card emits much less energy level than the electromagnetic waves emitted from other wireless devices (such as mobile phones). Wireless network card operates under the radio frequency safety standards and recommended codes of practice. These standards and recommendations reflect the consensus of the scientific community, as well as the results of a panel of scientists from the discussions and ongoing review and interpretation of a wide range of research literature. In certain situations or circumstances, the use of wireless network may be limited by the owner of the building or the responsible representative of the applicable organization.

The examples of such situations include:

- Use wireless network while on an airplane, or
- Use of wireless network in any other environment where the risk of harmful interference to other devices or services is known or determined.
- If you are unsure of the policies that apply to a particular organization or environment (such as airport) ask for authorization before you turn on your wireless network.

Limited Warranty

Warranty:

1. This product unit, battery not included, has a one-year limited warranty commencing on the date of purchase (Warranty Period Varies by Region). Free after-sales repair service will be provided in case of failure under normal use condition. Warranty for the accessories apart from the product unit is six months. In case the aforementioned warranty period is different from that on the product warranty card, the warranty period recorded on the product warranty card will supersede. The service does not apply to:
 - a. Appearance damage (such as scratches, dents, and other manmade marks).
 - b. Accessories apart from the product unit are consumables, but if caused by material or manufacturing defects are not subjects to this restriction.
 - c. Damages to the unit due to accidental abuse, misuse, flooding, fire or other natural disasters or accidents and other external causes.
 - d. Damages caused by unauthorized modification of software and hardware devices.
 - e. The product serial number cannot be identified.
 - f. Product degradation due to normal wear and tear.
2. When request for warranty repair, it is necessary to present the original purchase invoice or receipt/proof of purchase. Please contact the distributor when you made the purchase. The Xplova Repair and Maintenance Department will provide the warranty service according to the proof of purchase and the condition of device, or will provide a quote for repair.

* Note: If you do not bring or present a valid proof of purchase, and the warranty period can only be estimated by the unit manufacturing date from the serial number inquiry. This may result in the situation of outside the warranty period and need to pay for repair, therefore, please be sure to safe keep the proof of purchase.

Declarations

Please read this Instruction Manual carefully and safe keep this Instruction Manual for future reference. Please follow all the warnings and instructions specified on the product.

IMPORTANT SAFETY INSTRUCTIONS

- Please do not attempt to repair X5 Evo by yourself. Opening the case or removing the back cover may result in electrical shock or other hazards.
- Call Xplova before you send your X5 Evo for repair.
- X5 Evo can only be repaired by the qualified service personnel.
- If X5 Evo is physically damaged or malfunction, please stop using it. The physical damage is not limited to the examples listed as below: - Case is Broken or Cracked. - Button Fell Off. - Screen is Broken or Cracked. - Rubber Seal Fell Off. - Damage to parts of the Unit and other damages caused by the destruction of device seal.
- Overuse may damage your eyes.
- For long-term storage, please store the device within the specified temperature range (-10 ° C to 50 ° C).
- Discard your device in accordance with local regulations or contact your local waste disposal authority.

Copyright

The copyright ownership of this Instruction Manual belongs to Xplova Inc. This Instruction Manual, including all photographs, graphics and software, is protected by the International Copyright Laws and all rights are reserved. This Instruction Manual or any material, in whole or in part, contained herein shall not be reproduced in any form without prior written permission of the manufacturer / Xplova.

Battery Warning

Please follow the instructions below, if those guidelines are not followed, then the usage life of the lithium ion battery installed in the device may be abnormally shortened or cause fire resulted in risk of burns, battery electrolyte leakage, damage to the device, or cause personal injury.

- Please do not expose the device directly to heat or place it in high-temperature location, such as placing the unit unattended in the place under exposure of direct sunlight. To prevent loss of or damage to the device, remove the device from the bike or store it in a well-shielded carrying bag to avoid exposure to direct sunlight.
- Do not puncture or set fire to the device or battery.
- Do not remove the battery with any special tool.
- Other types of devices may use a replaceable coin battery. Make sure to follow the original manufacturer instructions to replace the battery to ensure safety.

Disclaimer

The information in this Instruction Manual is subject to change without notice. The Company does not claim nor guarantee the contents, and expressly refuse to assume any guarantee of the applicability for any specific purpose. The Company reserves the right to revise this document and to change its contents from time to time, and the Company undertakes no obligation to notify any person in advance of such revision of document or any information changed in the contents.

Trademark Identification

Xplova and Xplova logo are the company name and registered trademarks of Xplova Inc. Smart-Sign, Smart-Sign™ Guidance are the Trademarks of Xplova. All product names or trademarks of other company used in this Instruction Manual are for reference only and are the property of their respective owners.

European Union Declaration of Conformity

Xplova is here declared, this product is in compliance with the essential requirements and other relevant provisions or Directive 2015/53/EU.

Safety and comfort

Safety Instructions

Read these instructions carefully. Keep this document for future reference. Follow all warnings and instructions marked on the product.

Turning the product off before cleaning

Unplug this product from the wall outlet before cleaning. Do not use liquid cleaners or aerosol cleaners. Use a damp cloth for cleaning.

Warnings

Accessing the power plug

Be sure that the power outlet you plug the power cord into is easily accessible and located as close to the equipment operator as possible. When you need to disconnect power to the equipment, be sure to unplug the power plug from the electrical outlet. Mark sure the power plug is fixed at right position with the adaptor before plugging to the socket on the wall.

Input rating: Refer to the rating label on the device and ensure that your power adapter complies with the specified rating.

Under no circumstances should the user attempt to disassemble the power supply. The power supply has no user-replaceable parts. Inside the power supply are hazardous voltages that can cause serious personal injury.

A defective power supply must be returned to your dealer.

Using electrical power

- If an extension cord is used with this product, make sure that the total ampere rating of the equipment plugged into the extension cord does not exceed the extension cord ampere rating. Also,

make sure that the total rating of all products plugged into the wall outlet does not exceed the fuse rating.

- Do not overload a power outlet, strip or receptacle by plugging in too many devices. The overall system load must not exceed 80% of the branch circuit rating. If power strips are used, the load should not exceed 80% of the power strip's input rating.

General

- Do not use this product near water.
- Do not place this product on an unstable cart, stand or table. If the product falls, it could be seriously damaged.
- Slots and openings are provided for ventilation to ensure reliable operation of the product and to protect it from overheating.

These openings must not be blocked or covered. The openings should never be blocked by placing the product on a bed, sofa, rug or other similar surface. This product should never be placed near or over a radiator or heat register, or in a built-in installation unless proper ventilation is provided.

- Never push objects of any kind into this product through cabinet slots as they may touch dangerous voltage points or short-out parts that could result in a fire or electric shock. Never spill liquid of any kind onto or into the product.
- To avoid damage of internal components and to prevent battery leakage, do not place the product on a vibrating surface.
- Your device and its enhancements may contain small parts. Keep them out of the reach of small children.

Product servicing

Do not attempt to service this product yourself, as opening or removing covers may expose you to dangerous voltage points or other risks. Refer all servicing to qualified service personnel.

Unplug this product from the wall outlet and refer servicing to qualified service personnel when:

- The power cord or plug is damaged, cut or frayed.
- Liquid was spilled into the product.
- The product was exposed to rain or water.
- The product has been dropped or the case has been damaged.
- The product exhibits a distinct change in performance, indicating a need for service.
- The product does not operate normally after following the operating instructions. Note: Adjust only those controls that are covered by the operating instructions, since improper adjustment of other controls may result in damage and will often require extensive work by a qualified technician to restore the product to normal condition.

SAR information

RF exposure information (SAR)

This device meets the EU requirements (2014/53/EU) on the limitation of exposure of the general public to electromagnetic fields by way of health protection. The limits are part of extensive recommendations for the protection of the general public. These recommendations have been developed and checked by independent scientific organizations through regular and thorough evaluations of scientific studies. To guarantee the safety of all persons, regardless of age and health, the limits include a significant safety buffer.

Before radio devices can be put in circulation, their agreement with European laws or limits must be confirmed; only then may the CE symbol be applied.

The unit of measurement for the European Council's recommended limit for mobile devices is the "Specific Absorption Rate" (SAR). This SAR limit is 2.0 W/kg, averaged over 10 g of body tissue. It meets the requirements of the International Commission on Non-Ionizing Radiation Protection (ICNIRP). The maximum SAR value is calculated at the highest output

level in all frequency bands of the mobile device. The highest SAR value reported under this standard during product certification for use of the device at a distance of 0 cm from the body.

During use, the actual SAR level is usually much lower than the maximum value, because the mobile device works in different output levels. It only transmits with as much output as is required to reach the network. In general the following applies: The closer you are to a base station, the lower the transmission output of your device.

Disposal Instructions

Do not throw this electronic device into the trash when discarding. To minimize pollution and ensure utmost protection of the global environment, please recycle. For more information on the Waste from Electrical and Electronics Equipment (WEEE) regulations, please visit: www.acer-group.com/public/Sustainability/sustainability01.htm

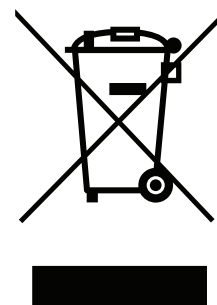

WELCOME

X5 Evo is a versatile cycling computer with an integrated action camera. A compact, efficient and rigid design makes it well-suited for a variety of indoor and outdoor bike activities. Designed with both “touch” and “button” functionalities, X5 Evo enables you to operate it under various weather and sports conditions. To obtain the best user experience, please read this manual carefully. It contains complete operating instructions and several useful tips. We hope you enjoy your cycling experience with X5 Evo.

Warning

Before you start or modify any exercise or training plan, please always consult your physician or other qualified health professional first. Please read details in section [Important Safety Instructions](#).

Download apps

To maximize your X5 Evo's availability/functionality, it is strongly recommended that you install our two apps on your smartphone:

- The **Xplova Connect** is a handy cycling app which helps you:
 - View/store activities from X5 Evo.
 - Download routes from websites.
 - Create and send routes/training plans to X5 Evo.
 - Upload your activities/routes on different platforms (e.g., Xplova, Strava and others).
- The **Xplova Video** is a video editing app which provides you with easy-to-use functions. It enables you to:
 - View/store videos from X5 Evo.
 - Video editing and production.
 - Overlay activity stats onto videos.
 - Post videos on social networks.

Open your smartphone's application store (Google Play or App Store) and search for "Xplova Video" or "Xplova Connect", then download and install the applications.

Alternatively, you can scan the QR Codes below to download them.

[insert QR code screenshot]

NOTE

- The Xplova Connect and Xplova Video require Android 5.0 (or later)/iOS 10 (or later) which supports Bluetooth 4.0 with BLE. Please check that your smartphone meets these requirements before downloading and installing the applications.



MEET YOUR X5 Evo

Package contents

X5 Evo comes with the following items. Contact your authorized dealer or distributor if any item is missing or damaged.

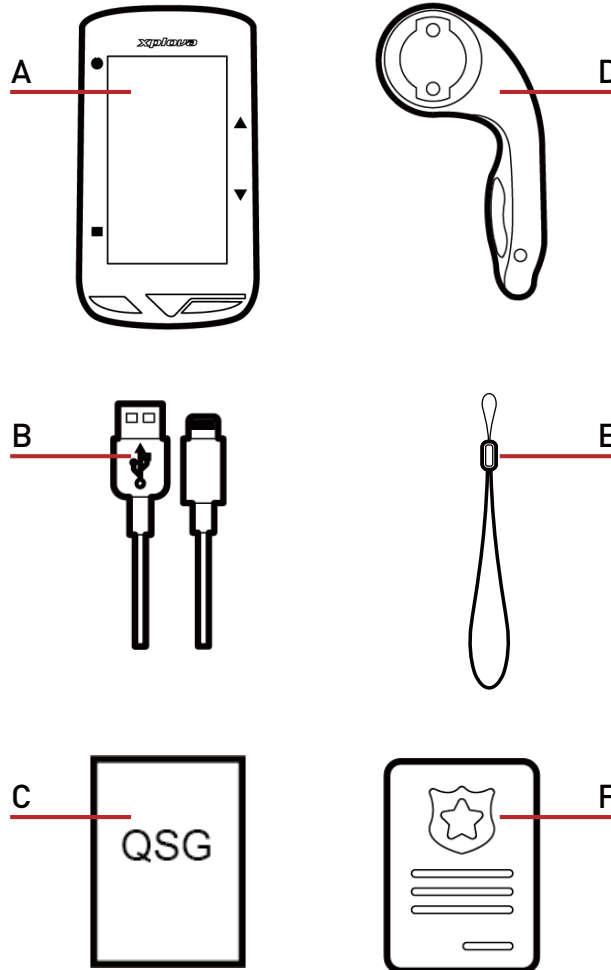

A. Smart Video Cycling Computer X5 Evo

B. Micro USB Cable

C. Quick Start Guide

D. Extended out-front Bike Mount Kit

E. Strap

F. Warranty Card

Optional accessories:

- Heart Rate Monitor
- Speed/Cadence Combo Sensor

NOTE

- Only use approved accessories.
- Accessories may vary by country or region.
- Please contact Xplova retailers if you need to purchase any optional accessories.

Getting to know your X5 Evo

- Front view

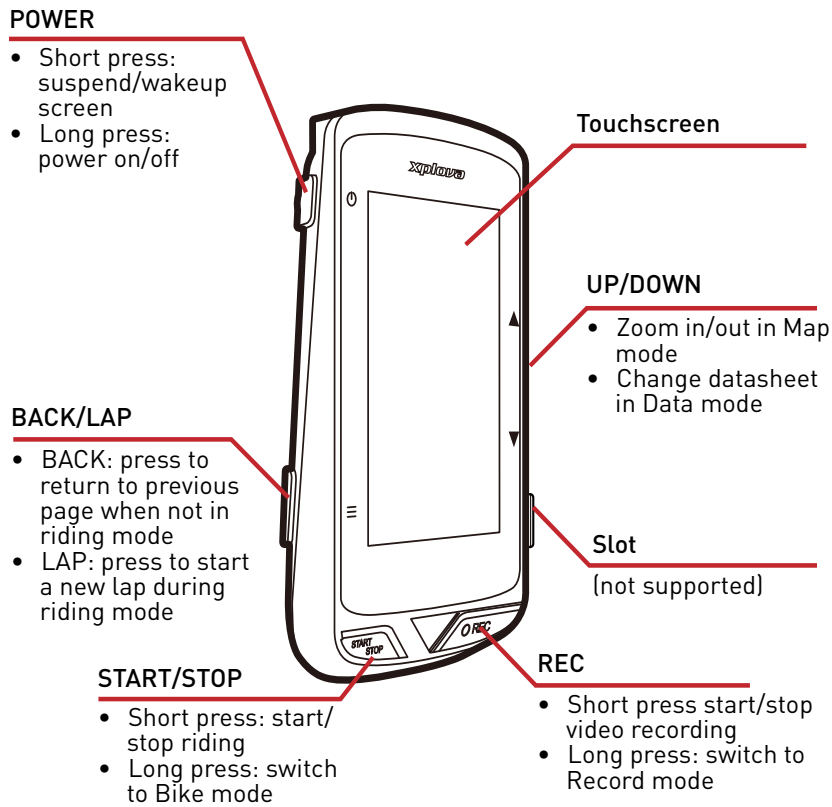

- Top view

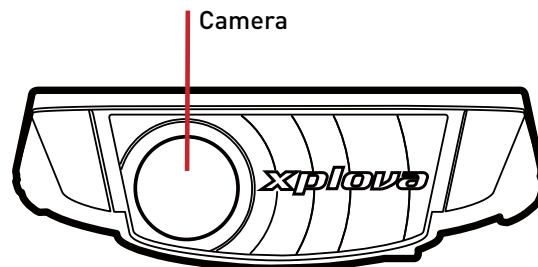

- Back view

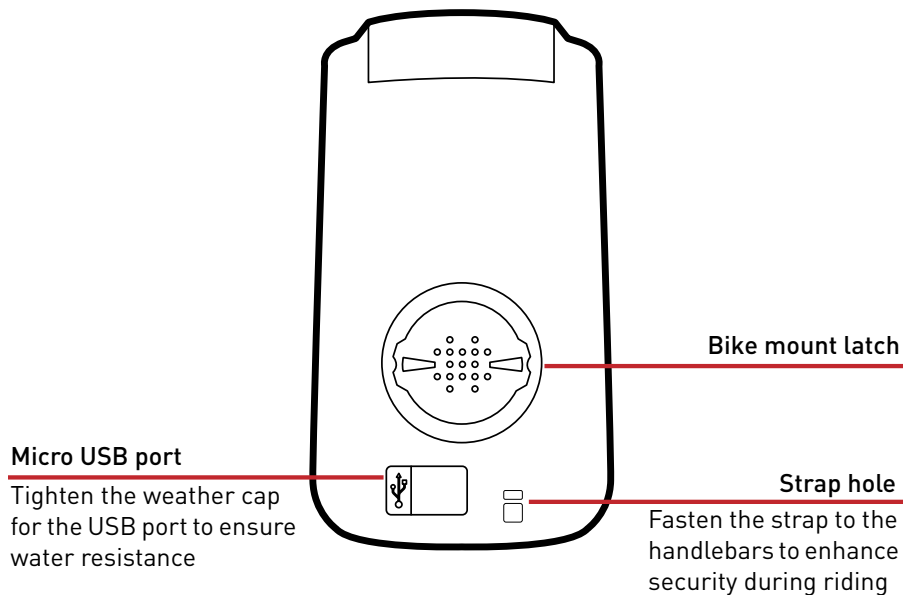

SETTING UP

Charging X5 Evo to 100%

For initial use, you need to charge the built-in battery (by the provided USB cable) for at least 5 hours. To prevent corrosion, thoroughly dry the Micro USB port, weather cap and the surrounding area before charging or connecting to a computer.

Please pull out the weather cap from the Micro USB port with care to avoid breakage. When charging process is completed, please ensure to put it back in snugly.

NOTE

- X5 Evo can be charged while using. Please be aware that the Micro USB port is not water-resistant. Do not attempt to charge X5 Evo in the rain or excessive moisture conditions.

Installing X5 Evo on the bike

To attach X5 Evo on your bike is quick and easy. Please follow the steps as below:

1. Attach the Extended out-front Bike Mount on the bike handlebar. Align it with the bike stem and tighten the screw. Ensure that the mount is securely locked and parallel with the ground level toward the front.

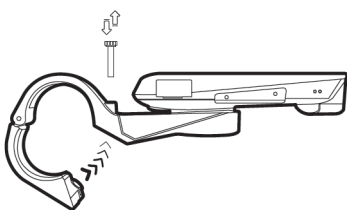

2. Hold X5 Evo firmly and turn it toward the right. Place it horizontally on the mount notch and press downward slightly.

3. Turn 90-degrees counterclockwise to lock it on the bike mount.

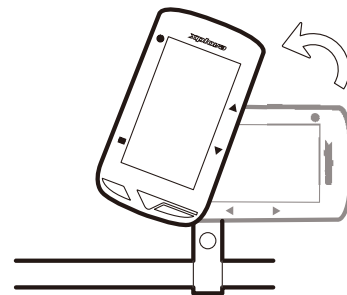

4. Eventually, X5 Evo is parallel to your stem. You can operate with ease.

Turning on X5 Evo

■ Performing the initial setup

Press and hold the [POWER] button to activate X5 Evo and follow the on-screen instructions to configure system settings.

1. Select display language.

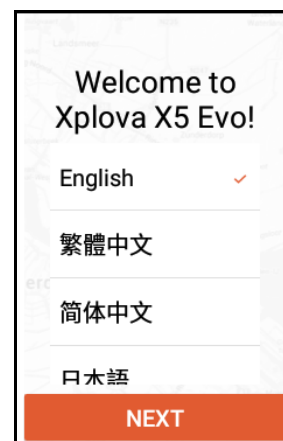

2. Select your time zone.

It is recommended to select **Set Automatically** to set the date and time based on your time zone.

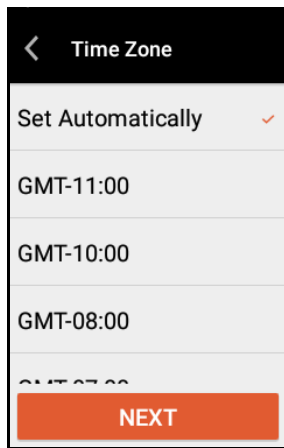

3. Select your preferred unit of measurement.

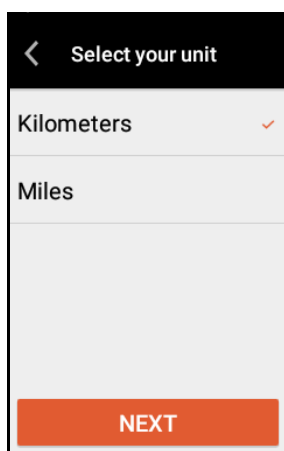

4. Create an Internet connection.



Enable Wi-Fi function and select **SEARCH FOR WI-FI NETWORK**. Choose a safe network and enter the password using the on-screen keyboard. Then select **CONNECT**.

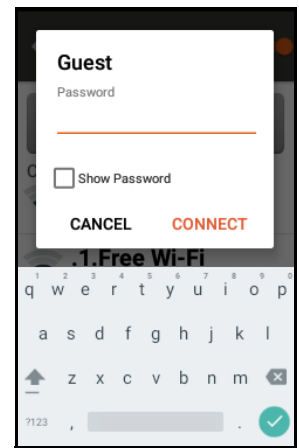

After reading and understanding the Warning message on the screen, select **OK** to finish the initial setup. Then you'll be brought to the Home screen.

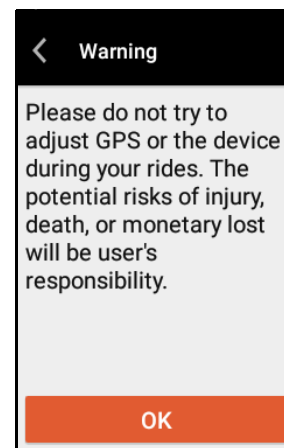

NOTE

- You can change these settings later in Settings menu.

Home screen overview

The Home screen is visually intuitive and user-friendly, with large size tiles and icons to quickly access to features and settings.

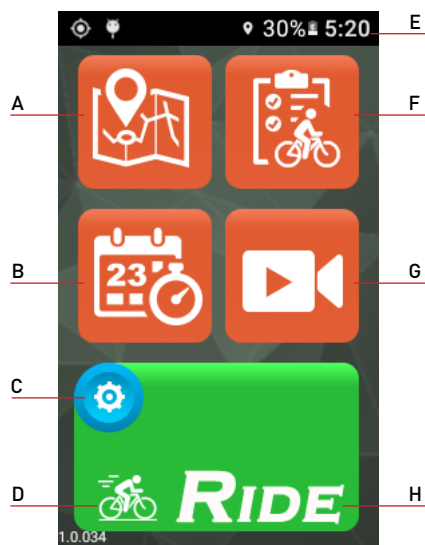

- A. Routes
- B. Training
- C. Settings menu
- D. Bike mode menu*
- E. Status bar
- F. Activities
- G. Video
- H. Ride mode (Start)

















* About Bike icon

From the Home screen, you may find a small bike icon  on the [RIDE] button. It shows which bike mode is currently being used.

Specifically tap on the bike icon (or long press [START/STOP] button) to bring up the Bike mode menu. There are four different bike modes for selection: Road (default), Off-Road, Leisure ride and Indoor.



Status bar icon

Icon	Description
	Status bar is full
	Paired with Heart Rate Monitor
	Paired with Speed/Cadence Combo Sensor
	Paired with Shimano Di2 Sensor
	Timer is paused
	Timer is running
	Paired with Power Meter
	Lap count
	USB connected
	GPS is located
	GPS is locating
	GPS is on
	BLE is on
	Audio is muted
	Wi-Fi is on
	Battery status
	Current time

NOTE

- Only the active icons are displayed on the status bar.

CYCLING WITH X5 Evo

WARNING: before you start or modify any exercise or training plan, please always consult your physician or other qualified health professional first.

NOTE

- The operating temperature range for X5 Evo is from -10°C to 50°C.
- Do not leave X5 Evo in high temperature (over 60°C) or damp environments.

Preparations

Please set some basic configurations to get more accurate ride information from X5 Evo.

1. Locate your GPS.

Go to **Settings > System > GPS**. Turn **GPS** switch to **ON**.

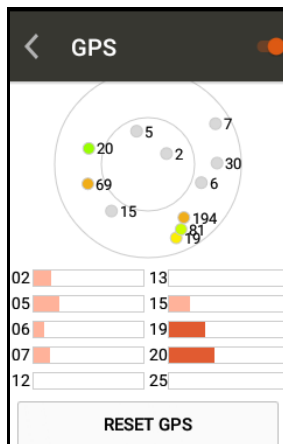

It may take several seconds to receive signals depending on the location. It is recommended to locate your GPS in an open area. Note that a weak GPS signal may cause your route and other activity data to be inaccurate.

* About GPS:

The number on the screen indicates the satellite number, and the color indicates signal strength.

- Grey: Weak
- Orange: Average
- Yellow: Good
- Green: Strong

The signal strength is also indicated in the bar chart, as shown in the image above.

In case of any abnormal positioning, such as locating at an open area for more than five minutes, please select **RESET GPS**.

2. Pair your X5 Evo with optional ANT+ Sensors (if available). (See [ANT+ Sensors on page 30](#))
3. Determine the wheel size and gears.

Go to **Settings > Bike**. In **Bike Setting** page, you can configure **Wheel Size**, **Front Gear Setting** and **Rear Gear Setting**.

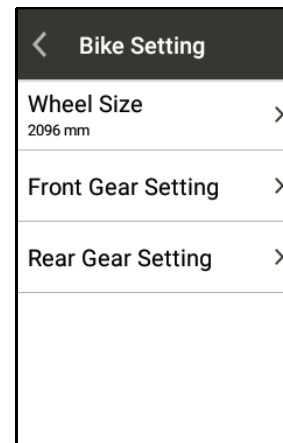

4. Calibrate your altitude.

Go to **Settings > Device > Altitude Calibration**.

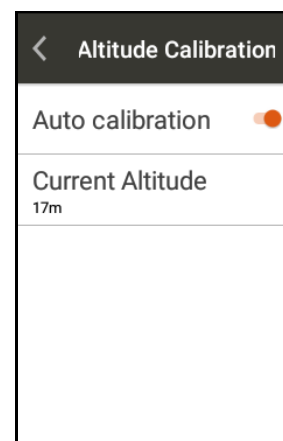

By default, it is set as **Auto calibration**. You can disable it and perform manual calibration.

Start a free ride

- From the Home screen, specifically tap on the bike icon  on the [RIDE] button* (or long press the [START/STOP] button) to bring up Bike Mode menu. Choose the most applicable one to your need.



- Tap [RIDE] button (or short press [START/STOP] button) to start riding.

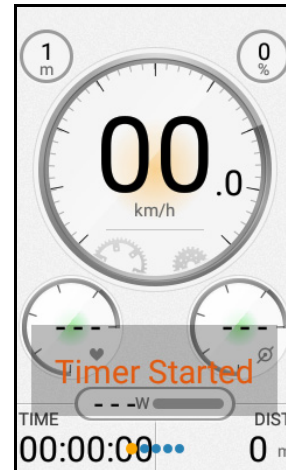

* About RIDE button:

The color of [RIDE] button changes depending on the riding status.

- When not in the riding mode, the [RIDE] button is green.
- When in the riding mode and the timer is running, the [RIDE] button is red.
- When the timer is paused, the [RIDE] button is orange.



- A Dashboard appears and the timer starts running. Swipe right or left to cycle through different pages to view cycling data in real time during riding or training.

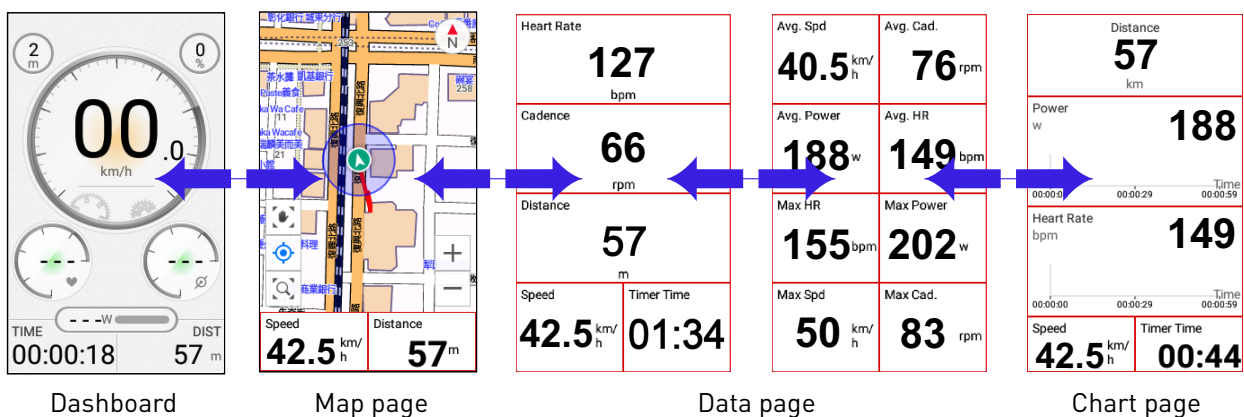

NOTE

- Pages may vary depending on which Bike mode you choose.

4. During riding, you can:
- tap on the touchscreen and select **STOP TIMER** to pause timer or **LAP** to start a new lap.



You can also:

- short press [LAP] button to lap. Or
- short press [START/STOP] button to pause timer and then select **CONTINUE**, **SAVE** or **DISCARD**.
- If you select **DISCARD**, a pop-up dialog box will appear on the screen to confirm the discard.

5. When timer is stopped, you can:
- short press [START/STOP] button to resume timer. Or
 - tap on the touchscreen to select **CONTINUE**, **SAVE** or **DISCARD**.

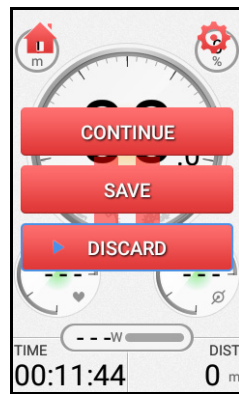
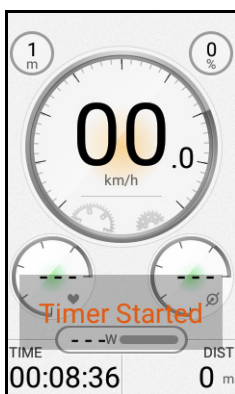

- Select **CONTINUE** to resume timer.
- Select **SAVE** to save the riding data into **Activities** (See [Activities on page 21](#)).
- Select **DISCARD**, a pop-up dialog box will appear on the screen to confirm the discard.

Page introduction

■ Dashboard

The Dashboard provides plenty of cycling data at a glance.

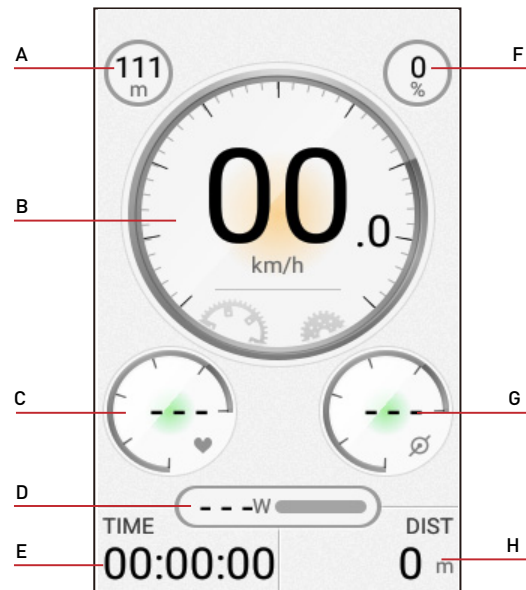

- | | |
|----------------|-------------------|
| A. Altitude | E. Trip time |
| B. Speed | F. Slope |
| C. Heart rate* | G. Cadence* |
| D. Power* | H. Total distance |





ⓘ NOTE

- The heart rate, power and cadence data will not display if you have unpaired those optional accessories.
- It is not allowed to customize any data or edit layout in the Dashboard.

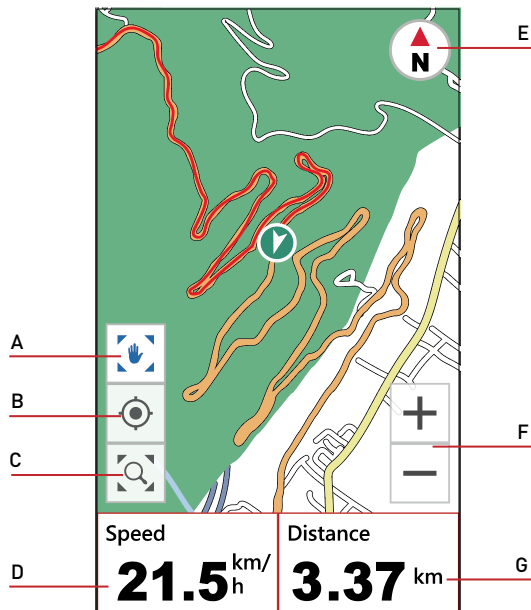
Map page

Support offline maps, find your current location, obtain route-related details and etc.



- Toggle between  (lock map) and  (unlock map).
- Fit your current location on the center of map.
- Show your riding track in Map mode. Or show your route in Navigation mode.
- Data field.
- Toggle between  (Track Up view) and  (North Up view).
- Zoom in/out the map.
- Data field.

Data and Chart pages

Depending on your choice of Bike mode, X5 Evo provides a range of data on different pages, including distance, speed, time and more.

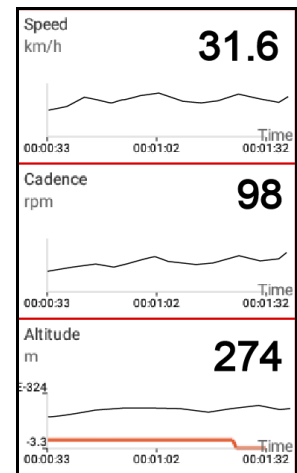
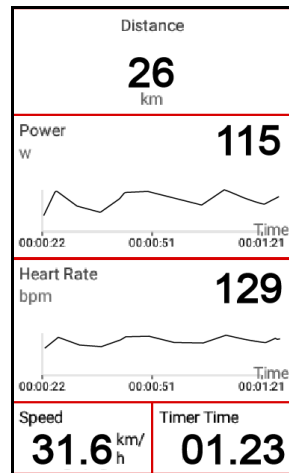
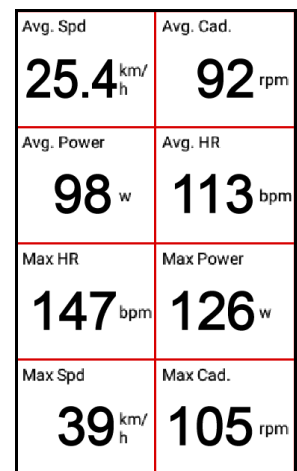
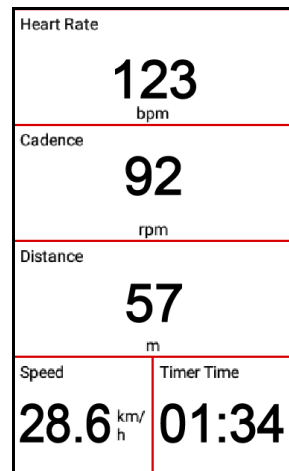

NOTE

- You can press [UP/DOWN] button to increase or decrease the number of data fields.

Quick Access Menu

Swipe down from the top of the screen to access the **Quick Access Menu**. You can adjust brightness/volume and configure the advanced settings of GPS, altitude and network. Tap  to close the **Quick Access Menu**.

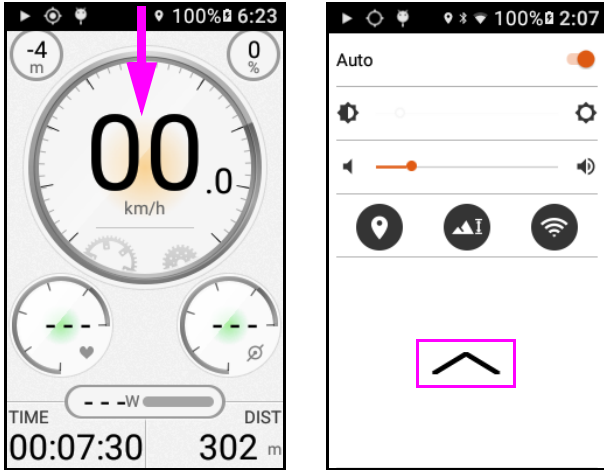

Data field customization

X5 Evo allows you to customize data fields on specific pages before starting the ride or on mid-ride to get important data and numbers.

- **To change the data fields on Map page:**
 1. From **Settings > Bike mode**, select one of Bike modes, for example "Road".

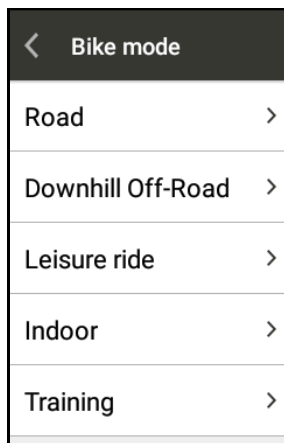

2. Select what data you would like to see on Map page.
 - Select **Map > Edit**.

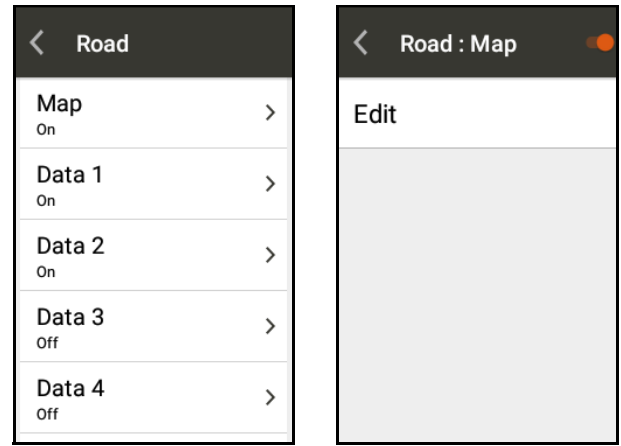

- Two data fields under the Map can be customized according to your preference.

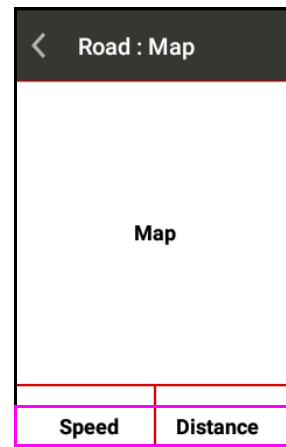

- Select a data field to enter **Select content** page. Select the desired data to see on Map page.

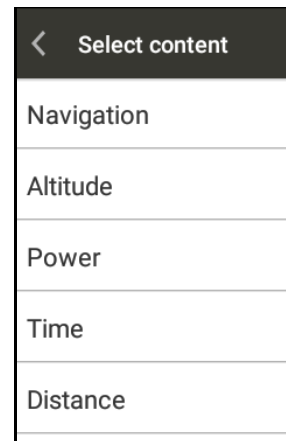

- **To change the data fields on Data page:**
 1. Select a **Data** page, for example "Data 1".
 - Select **Change layout** and choose a desired grid number of data field.

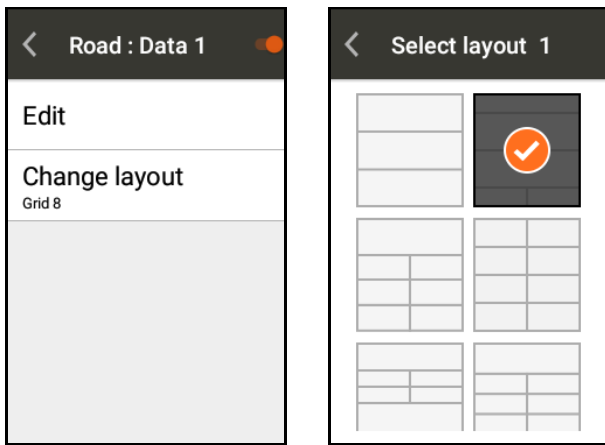

- Select **Edit** and a data field you want to change. In **Select content** page, select the desired data to see on Data page.

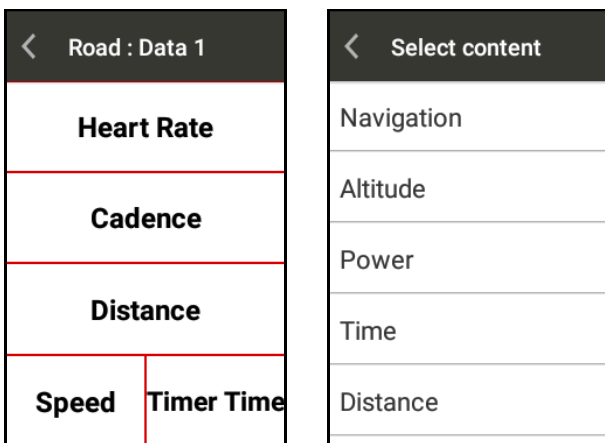

2. Repeat the steps above for other data fields.
- **To change the data fields on Chart page:**
 1. Select a **Chart** page, for example "Chart 1".
 - Select **Change layout** and choose a desired grid number of data field.
 - Select **Edit** and a data field you want to change. In **Show Settings** page, select the desired data to see on Chart page.

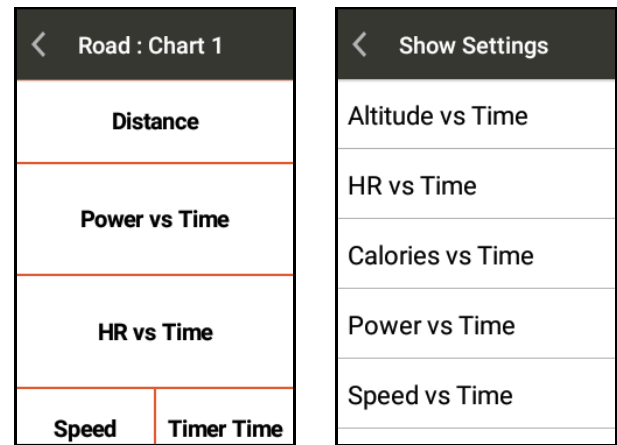

2. Repeat the steps above for other data fields.
 - **To change the data fields during riding**
Tap on the touchscreen, then two icons appear at the top of the screen: Home 🏠 and Settings ⚙️.

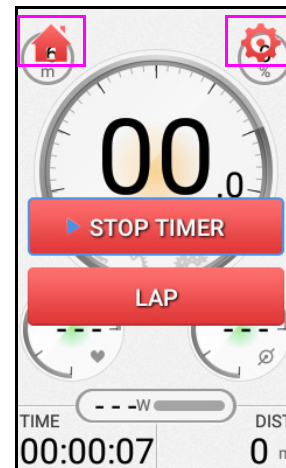

- Tap Home icon 🏠 to go back to the Home screen.
- Tap Settings icon ⚙️ to enter its page overview of the current bike mode. From here, the layout of the Data/Chart pages can be customized or add/delete a page.

NOTE

- You can long press a data field directly to change it even if the timer is running.
- Your X5 Evo can display up to:
 - 4 custom Data pages (3 - 11 fields of data for each).
 - 3 custom Chart pages (3 - 5 fields of data for each).

- If the maximum number of pages have been reached, a prompt message will pop up to remind you to delete one of the pages before adding a new page.

Alert settings

X5 Evo allows you to set different alerts to notify you with an alert message when you've exceeded the pre-specified value or interval in riding mode.

- Setting Time, Distance and Calorie alerts:
1. Go to **Settings > Device > Alert Settings**.
 2. In **Alerts** page, select **Time, Distance** or **Calories**.

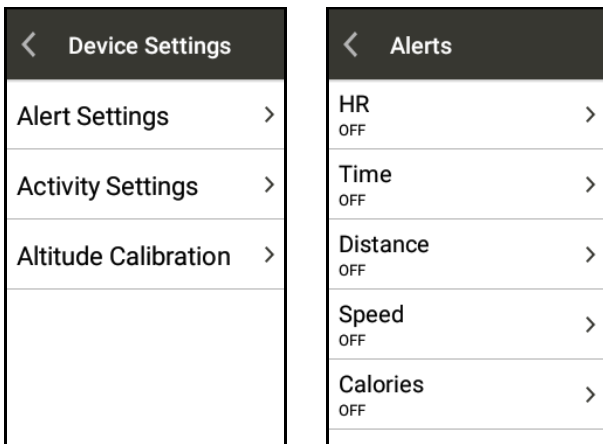

3. Turn **Time, Distance** or **Calories** switch to **ON**.
4. Enter a value using the on-screen keyboard.

For example, you can set the Time alert to remind you every 10 minutes repeatedly.

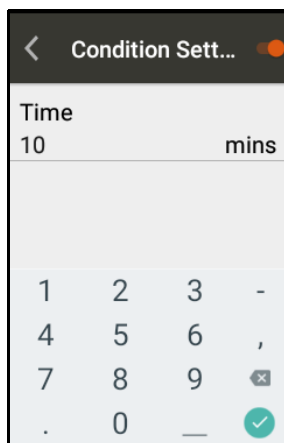

- Setting advanced alerts:
If you have optional ANT+ sensors, you can set up advanced alerts.
1. Go to **Settings > Device > Alert Settings**.
 2. In **Alerts** page, select **HR, Speed, Power** or **Cadence**.
 3. Turn **HR, Speed, Power** or **Cadence** switch to **ON**.
 4. Enter a value using the on-screen keyboard.

NOTE

- The alert message will pop up at the bottom of the screen. Tap **X** to close it. If you want to disable any alert setting, go to **Settings** and turn them **OFF**.

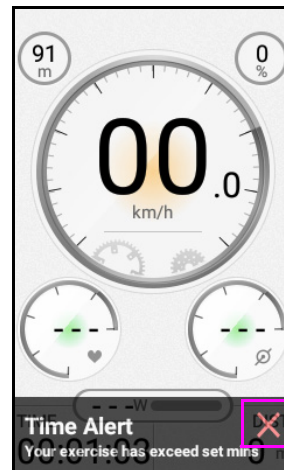

- To adjust audible tones for alert messages, please see [Sounds on page 41](#).

Activity settings

Auto Lap

This feature automatically creates a new lap at a pre-specified distance in riding mode, so that you can accurately track how many laps you have done over a ride without having to press [LAP] button.

1. Go to **Settings > Device > Activity Settings**.

- Turn **Auto Lap** switch to **ON**.

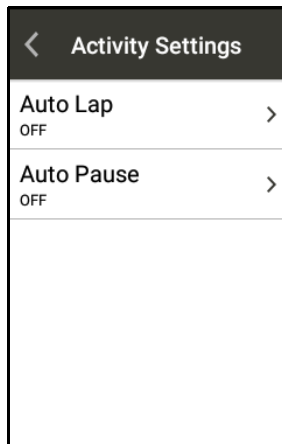

- Set a distance for the automatic lap using the on-screen keyboard.

■ Auto Pause

You can use this feature to pause the timer automatically when your speed drops below a pre-specified value in riding mode (default is 2 km/h). When moving, a “Detect movement” message will display at the bottom of the screen to remind you to start the timer by pressing [STRAT/STOP] button.

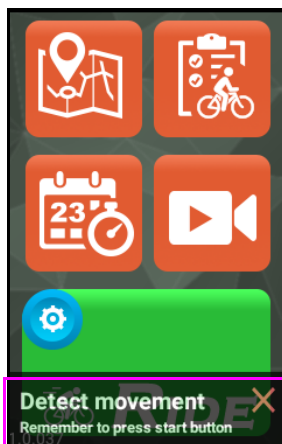

- Go to **Settings > Device > Activity Settings**.
- Turn **Auto Pause** switch to **ON**.
- Set a speed for the automatic pause using the on-screen keyboard.

Map download

The local map is preloaded on your X5 Evo. What makes it even better is the free worldwide maps for offline use. If you plan to use X5 Evo in a foreign country, you may download the map correspondent with the country you visit.

■ Download maps

- Go to **Settings > My Map > Download Maps**.

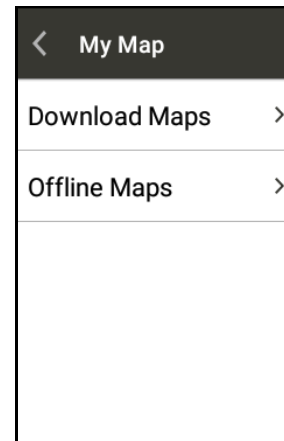

- Select the desired region and country, then download the map by tapping  from the list.

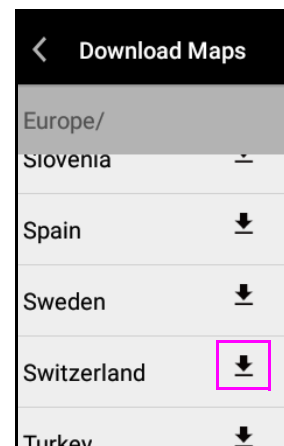

- A pop-up dialog box will appear on the screen, displaying the size of map file and remaining storage. Select **Load** to start downloading; or select **Cancel** to discard.

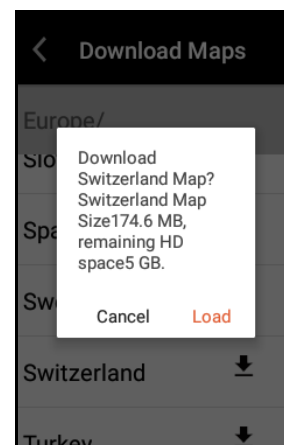

4. After downloading is completed, a remark of “Download Completed” will display next to the country name.

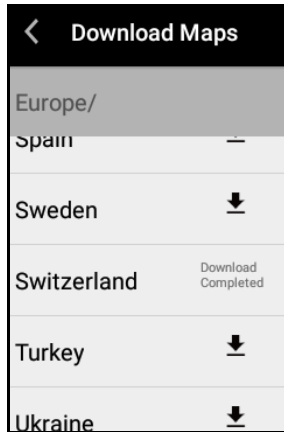

5. Select **Settings > My Map > Offline Maps** to view the list of your offline maps.

NOTE

- Please make sure Wi-Fi is connected before downloading.
- Only one map can be downloaded at a time.
- By default, the offline maps are downloaded on your X5 Evo internal storage. If the storage is insufficient, a failure message will appear on the screen. It is recommended to delete the map files that are temporarily not in use to free up the storage.

Delete maps

1. Go to **Settings > My Map > Offline Maps**.
2. Tap  at the upper-right corner of the screen and check the box next to the country name which you want to delete.
3. Tap **Delete** to delete the selected map.

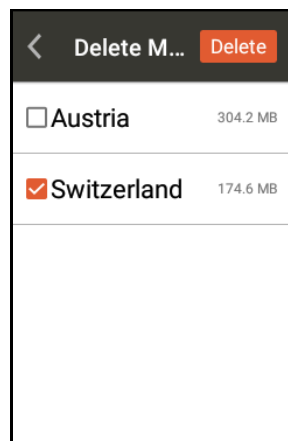
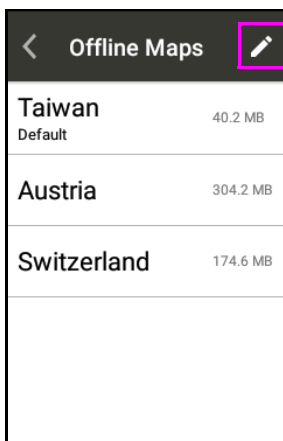

NOTE

- Your X5 Evo is already preloaded with local map which is unable to delete.

ACTIVITIES

View activity

Tap Activities  on the Home screen to display the recorded activity list. Each activity is given a name based on YYYY-MM-DD format.

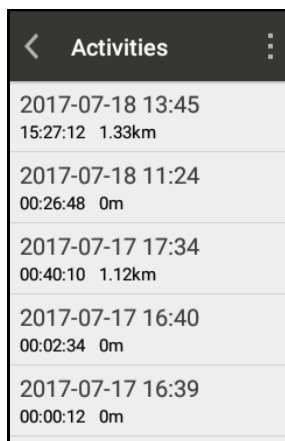

Select an activity, you will see the overview of the cycling data, including graphical analyses with your speed, altitude and temperature at different points.

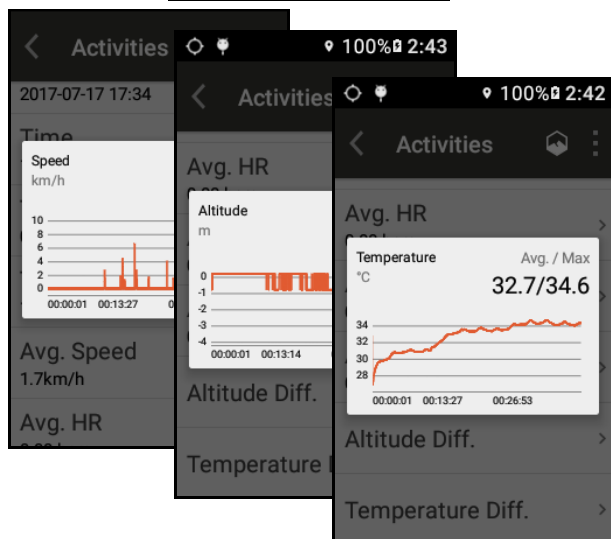
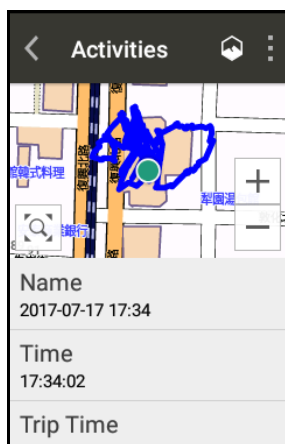

Delete activity

Tap  at the upper-right corner in Activity list page and select **Edit**. Check the box next to any activity name and tap **DELETE**.

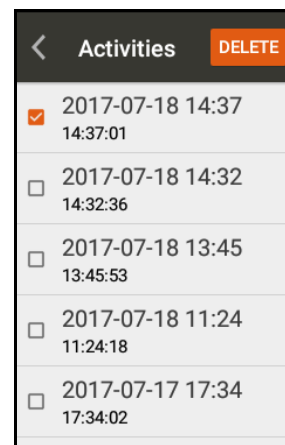
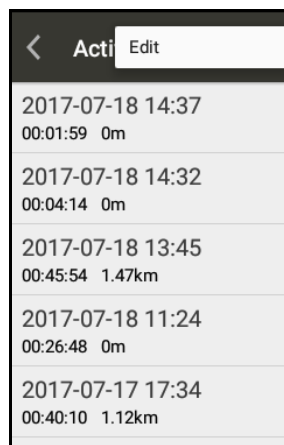

NOTE

- Make sure Xplova Connect app is launched and connected to X5 Evo.
- Learn more on how to pair devices, please see [App Tutorial on page 32](#).

Challenge mode

With this feature, you can challenge yourself to break your previous activity record or compare with different results to improve your performance.

1. Select an activity you want to challenge in **Activities** list.
2. Tap  to start the **Challenge Mode**.



Close current route or challenge



- Once Challenge Mode ends, the result based on the completion rate and time of this record will be displayed.
- Tap **DONE** to save and read the recorded activity data.

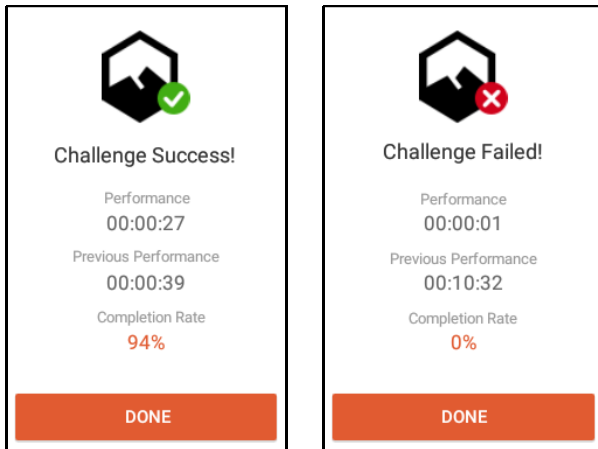

Upload activity

Once your X5 Evo has been paired and connected to your smartphone, all activity data will be synced automatically.

For more information on data synchronization between your X5 Evo and smartphone, please refer to [Xplova Connect on page 32](#).

Unfinished activity

If X5 Evo shuts down unexpectedly on some occasions, it may detect an unfinished activity after reboot. A dialog box will pop up asking you for further action.

- Select **CONTINUE** to continue the activity.
- Select **SAVE** to end and save the activity.
- Select **DISCARD** to cancel the activity.

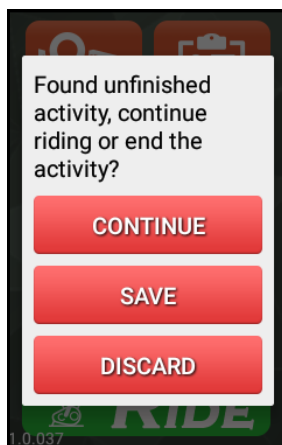

VIDEO

X5 Evo is equipped with a video camera capable of recording HD 720p/30fps, with a 120-degree wide-angle lens to capture exciting moments when riding.

Choose record mode

X5 Evo supports four record modes: Manual (default), Auto, Loop and Time-lapse.

Go to **Settings > Record Settings > Select REC mode**. Then select your desired record mode.

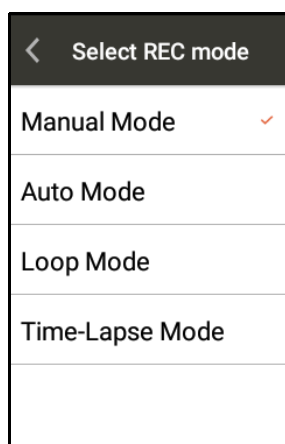

Setup record mode

After you've chosen the Record mode, go to configure further settings.

Go to **Settings > Record Settings > Record mode settings**.

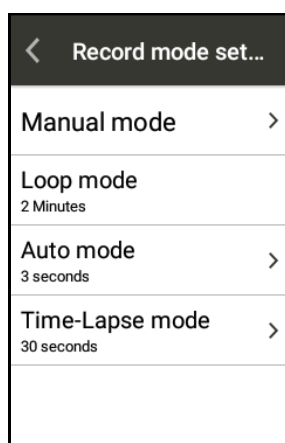

- **Manual Mode**

While riding, you can manually short press [REC] button to start recording videos at any time. Short press [REC] button again to stop recording.

- Live video preview

Go to **Settings > Record Settings > Record mode settings > Manual mode**.

Turn **Live video preview** switch to **ON** (default). A wide angle camera preview screen will display on X5 Evo to show live recording when performing a manual record.

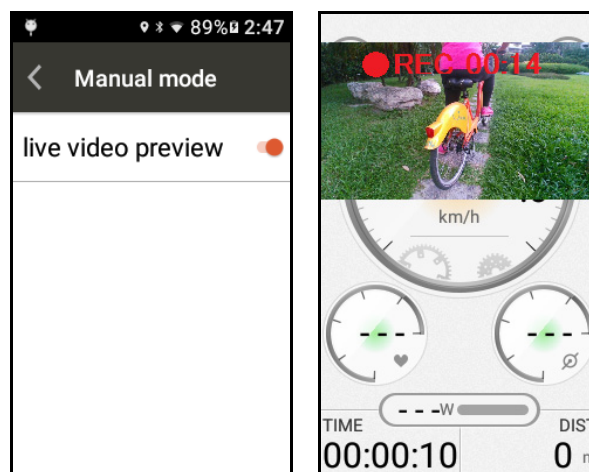

If you don't need a camera preview, turn **Live video preview** switch to **OFF** to disable it.

- **Auto Mode**

The **Auto Mode** allows you to set up auto-record triggers and specify the length of the auto recording.

When an event triggers the auto recording in riding mode, the function of the [REC] button is inactive.

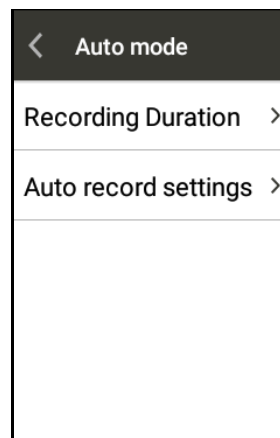

- **Recording Duration**

Specify the video recording length. Available options: **3/6/9/15/30** seconds.

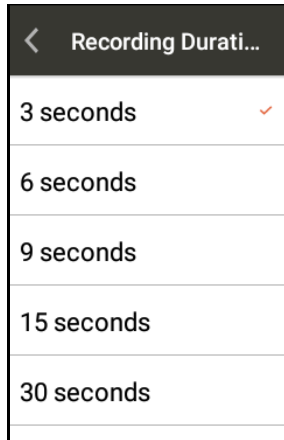

- **Auto record settings**

Turn **Auto REC** switch to **ON**. Select the desired options and configure the condition settings that will be used to trigger the auto record feature.

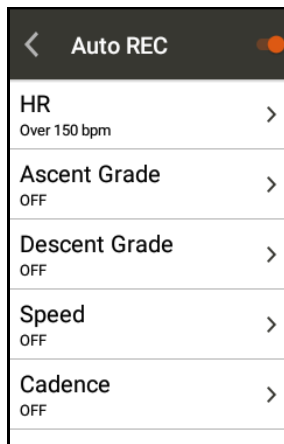

For example:

A. If **Time** is set to 5 minutes and **Recording Duration** is set to 3 seconds: X5 Evo will record a 3-second video in every 5 minutes automatically.

B. If **HR** is set to 150 bpm and **Recording Duration** is set to 3 seconds: X5 Evo will continually record 3-second videos whenever the heart rate is over 150 bpm. Auto recording will stop when the heart rate drops below 150 bpm.

C. If multiple events are triggered at the same time, X5 Evo will only record once at a specified duration.

• **Loop Mode**

If the **Loop Mode** is selected, X5 Evo will activate the looping record while you start riding mode simultaneously. It allows a maximum of 10 videos looped recording. By default, the recording time for a single video file is 2 minutes. When it reaches the file limitation, it will start overwriting the oldest files.

You can short press [REC] button to stop recording in riding mode when the **Loop Mode** is chosen.

• **Time-Lapse Mode**

The **Time-Lapse Mode** allows you to record individual video files at a certain shot duration that you choose.

If the **Time-Lapse Mode** is selected, you can short press [REC] button to stop recording in riding mode.

- **Shooting interval**

Specify the interval time of video recording.

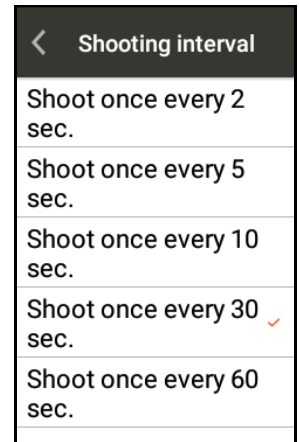
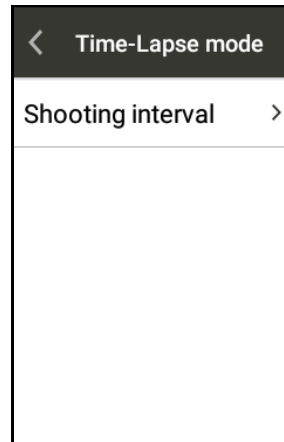

NOTE

- When you swipe down from the top of the screen to invoke the Quick Access Menu during recording:



REC mode \ Status	When Quick Access Menu is open	When Quick Access Menu is close
In Manual Mode	Auto Stop REC	Manually Restart REC
In Loop Mode	Auto Stop REC	Auto Restart REC
In Time-Lapse Mode	Auto Stop REC	Auto Restart REC

Mute recording

X5 Evo allows you to record with or without external sound in Record mode.

1. Turn **Mute recording** switch to **ON** to record your video without sound.
2. Turn **Mute recording** switch to **OFF** to record your video with sound.

View video

1. Tap  on the Home screen to open the video preview screen.
2. Tap the folder icon  at the bottom left of the screen.

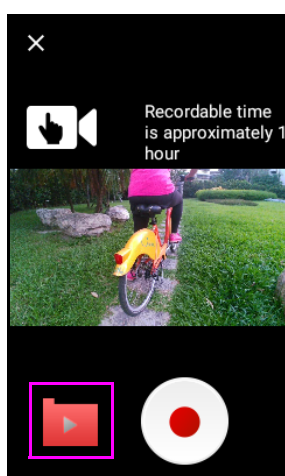

3. Select the folder which you want to view the recorded videos.

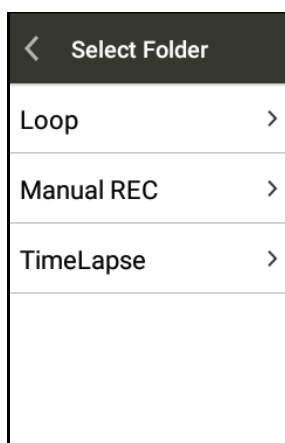

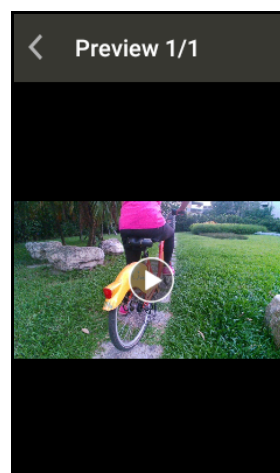

4. Each recorded video is given a name based on YYYY-MM-DD format. Select one and tap  to play.



NOTE

- There is a message displaying at the bottom of the screen to show you the remaining recordable time for video recording.
- The videos recorded in the Time-Lapse mode cannot be played on X5 Evo. Please watch/edit the Time-Lapse mode videos using Xplova Video app. (See [Xplova Video on page 36.](#))

Delete video

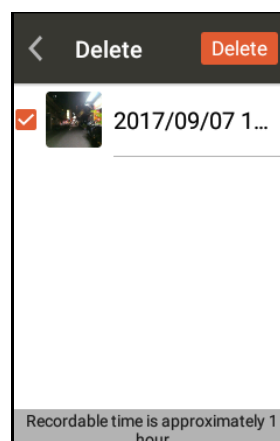

1. Tap  on the Home screen to open the video preview screen.
2. Tap the folder icon  at the bottom left of the screen.
3. Select the folder which you want to delete the recorded videos.
4. Tap  at the upper-right corner of the screen and select **Edit**.
5. Check the box next to any video clip and tap **Delete**.





Record preview mode

You can use Video feature as a video camcorder to take video clips when not in riding mode.

1. Tap  on the Home screen to open the video preview screen.
2. Select a record mode.

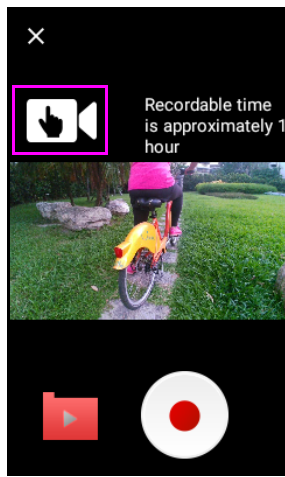
Tap the icon at upper-left corner of the screen to cycle through mode options: [Manual] , [Loop]  and [Time-Lapse] .



3. Tap  icon to start recording.
Tap  icon to stop and save recording.

NOTE

- There is a message displaying at the bottom of the screen to show you the remaining recordable time for video recording.
- Any changes you make to the Record preview mode do not affect the **Record Settings** in **Settings** menu.

Upload video

For more information on how to upload video files to your smartphone, please refer to [Xplova Video on page 36](#).

TRAINING

Download a training plan

Before you can start a training plan on your X5 Evo, you need to download a plan on your smartphone and sync with X5 Evo. For more information, please refer to chapter [App Tutorial](#).

Start a training plan

1. Tap  on the Home screen to display the downloaded training plans.
2. Select a training plan that fits your need.

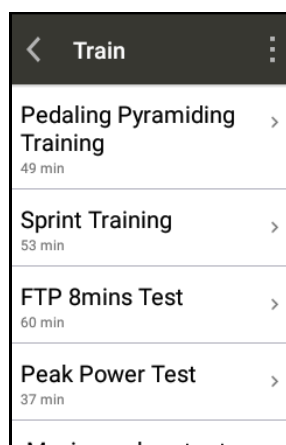

3. An overview of the entire training plan is available to allow you to see how it progresses.
4. Select **Start** to start the training plan.
5. X5 Evo displays each training step with the goals. Follow the training plan to complete the tasks step by step.

If you failed a step, the **Target not Achieved** message displays to remind you of the failure.

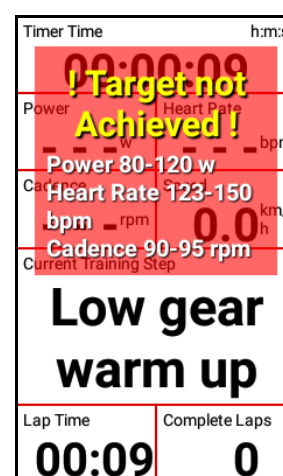
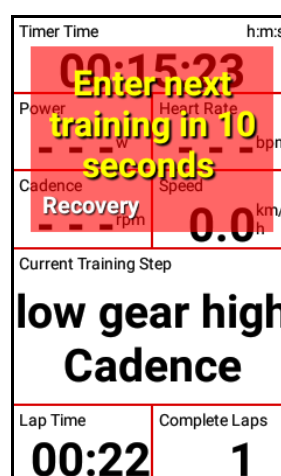
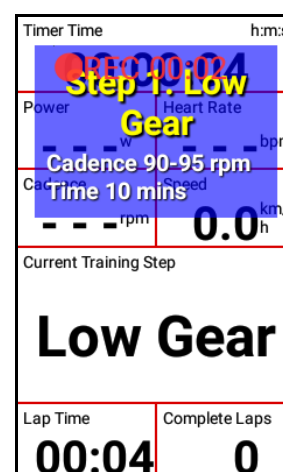
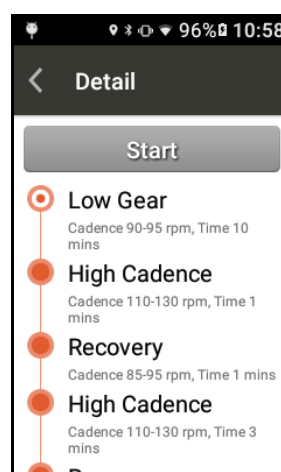

NOTE

- Press **UP/DOWN** button to increase or decrease the number of data fields in the Training mode.
- You can long press a data field to change it in the Training mode.
- You will need a heart rate Monitor and combo sensors to display the heart rate zone, power and target cadence specified in different steps during training.
- Before you start on a new training plan, please always consult your physician or other qualified health professional first.
- You must rest and recover to ensure that the training plan is beneficial to you.

Stop a training plan

1. Short press [START/STOP] button, select **SAVE** to end and save the training plan into Activities. Or select **DISCARD** to cancel it.

Alternatively, you can:

2. Tap on the touchscreen and select **STOP TIMER** and tap again to select **SAVE** or **DISCARD** the training plan.
3. If you select **DISCARD**, a pop-up dialog box will appear on the screen to confirm the discard.

Delete a training plan

1. Tap  at the upper-right corner on the Train page and select **Edit**.
2. Check the box next to the training plan which you want to delete and tap **DELETE**.

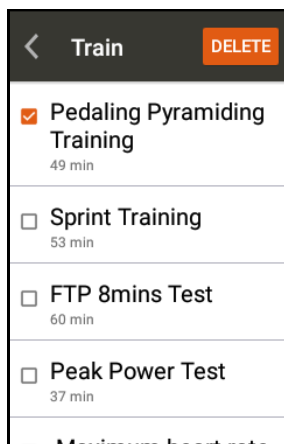



ROUTE

Download a route

Before you can start a route on your X5 Evo, you need to download a route on your smartphone and sync with X5 Evo. Please refer to chapter [App Tutorial](#).

Start a route

Tap Routes  on the Home screen to display the downloaded route list.

1. Select a route, the track will display on the map and mark with SmartSign™ (if available).
2. Tap  at the upper-right corner of the screen to view route details.

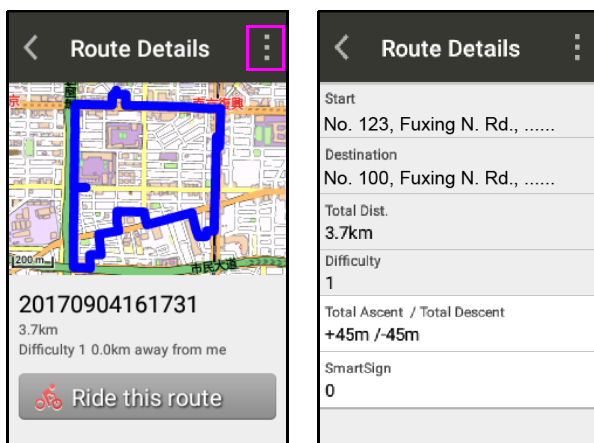

3. Tap **Ride this route** to start riding. Tap  icon to close the route.

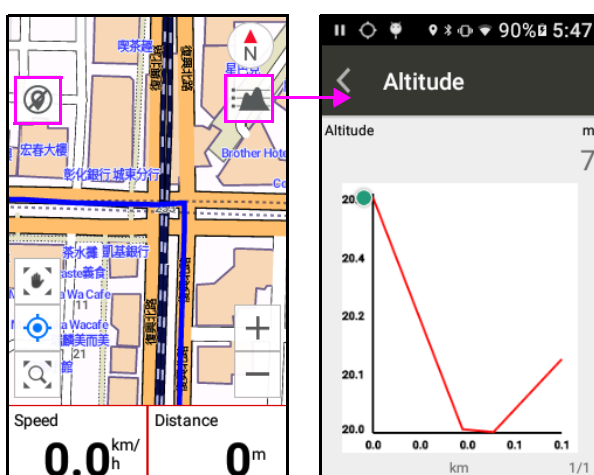

Stop a route

1. Short press [START/STOP] button, select **SAVE** to end and save the route into Activities. Or select **DISCARD** to cancel the route.

Alternatively, you can:

2. Tap on the touchscreen and select **STOP TIMER** and tap again to select **SAVE** or **DISCARD** the route.
3. If you select **DISCARD**, a pop-up dialog box will appear on the screen to confirm the discard.

Delete a route

1. Tap  at the upper-right corner on the Routes page and select **Edit**.
2. Check the box next to the route which you want to delete and tap **Delete**.

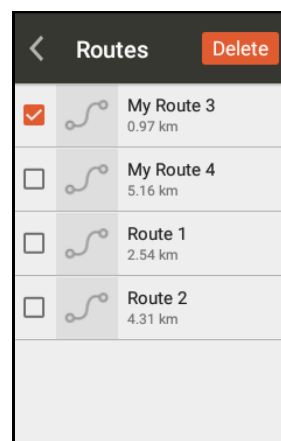

NOTE

- Smart Signs provide guidance and messaging functionalities which give you accurate directions on every junction of your route, and keep you on the top of the upcoming Smart Sign, such as the distance to the next waiting/resting point, distance to the next slope and its length and elevation, etc.

ANT+ SENSORS

X5 Evo has a built-in 2.4GHz ANT + digital wireless receiver which supports standard ANT + wireless peripherals. The peripheral sensor information can be accurately retrieved through digital wireless signal, with characteristics of low power consumption and anti-interference. Currently, the supported ANT+ peripheral sensors are: Heart Rate Monitor, Combo Sensors (including Speed and Cadence), Cadence Sensor, Speed Sensor, Power Meter and Shimano Di2. For more details about compatibility, please contact Xplova customer service at: service@xplova.com.

■ Heart Rate Monitor

1. Turn on Heart Rate Monitor and wet the electrodes and the contact patch to ensure a proper connection.
2. Warp your Heart Rate Monitor snugly around your chest. The monitor segment is placed in the middle of your chest.
3. From X5 Evo, tap **Settings > ANT+ Sensors**. In **ANT+ Sensors** page, select the **Heart Rate Monitor** and tap **Search Again**. If available device is found, the sensor ID will appear on the screen.

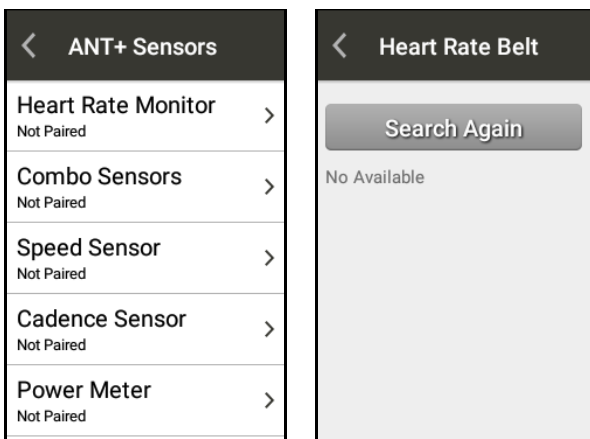



4. The heart rate data will appear in the Dashboard and data page or a custom data field. The  icon will display on the status bar when data is being transmitted or received by X5 Evo.
5. If you would like to disconnect with the device, long press the sensor ID of the current paired device, and the call-to-

action window will pop up. Select **REMAIN** to stay connected or **DELETE** to disconnect with the device you choose.

■ Combo Sensors

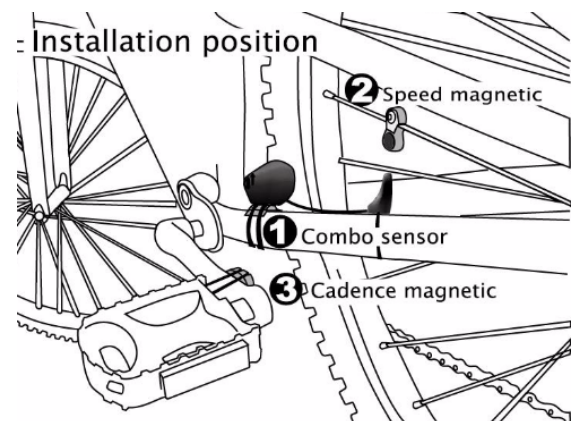
X5 Evo supports all ANT + specification combo sensor. It is highly recommended to use the combo sensor from the Xplova original optional accessories for the best results. The Combo sensors (including cadence and speed sensors) is installed on the rear pedals and above the rear chain. After installation, it will detect your speed and cadence accurately without being affected by weather or topography. Please refer to the picture below or the instructions included with the sensor to install the combo sensor.



1. From X5 Evo, tap **Settings > ANT+ sensors**. Select the specified sensor from **ANT+ Sensors** page and tap **Search Again**.
2. Tap the desired device.
3. Wait until the pairing process is completed, the screen will display the number of the connected device.
4. On the Dashboard, the speed and cadence icons will appear in orange color, indicating the device has been paired successfully. The corresponding icon  will display on the status bar when data is being transmitted or received by X5 Evo.
5. If you would like to disconnect with the device, long press the sensor ID of the current paired device and the call-to-action window will pop up. Select

REMAIN to stay connected or **DELETE** to disconnect with the device you choose.

 **NOTE**

- If you use the speed sensor sold separately and the wheel size is different, please set the wheel size first. The wheel size is set as 2096 mm by default.

Select **Settings > Bike > Wheel Size** to set the wheel size.

■ **Shimano Di2**

1. From X5 Evo, tap **Settings > ANT+ sensors > Shimano Di2**, tap **Search Again**.
2. Tap the desired device.
3. Wait until the pairing process is completed, the screen will display the number of the connected device.

Please refer to documentation of Shimano Di2 for usage and installation.

APP TUTORIAL

NOTE

- Xplova Connect and Xplova Video apps are specially designed to work with X5 Evo. Please download them on your smartphone either from the Google Play or App Store.
- In addition, to download video clips from your X5 Evo to Xplova Video app on your smartphone, you must install Xplova Connect app first and have your X5 Evo and smartphone paired already.

Xplova Connect

The **Xplova Connect** is a handy cycling app to store, analyze, create and send your activities, routes and training plans among the smartphone, X5 Evo and social platforms.

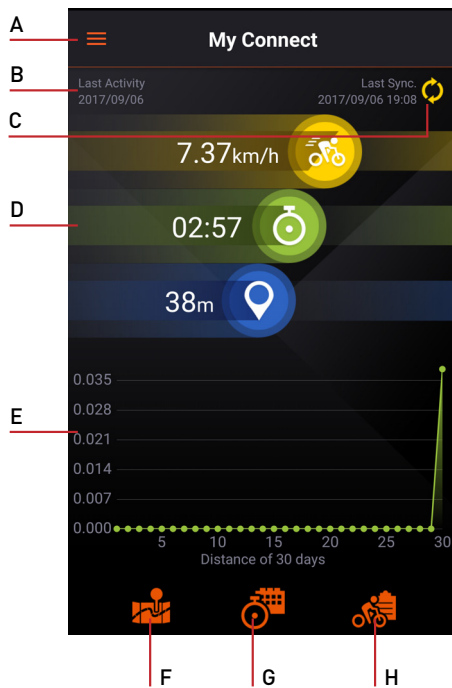

- | | |
|---|--|
| A. Open Side menu | E. Show the distance of the past 30 days |
| B. Show the date of the last activity | F. Go to My Route |
| C. Show the time that last sync with X5 Evo | G. Go to Training |
| D. Show the total speed/time/distance of the past 30 days | H. Go to Activity |

How to pair/unpair devices

- Pair

Follow the steps below to pair X5 Evo with your smartphone.

1. Launch the Xplova Connect app on your smartphone.
2. Either tap icon at the upper-left corner on My Connect screen or swipe right from the left edge of the screen to pull open the Side menu.

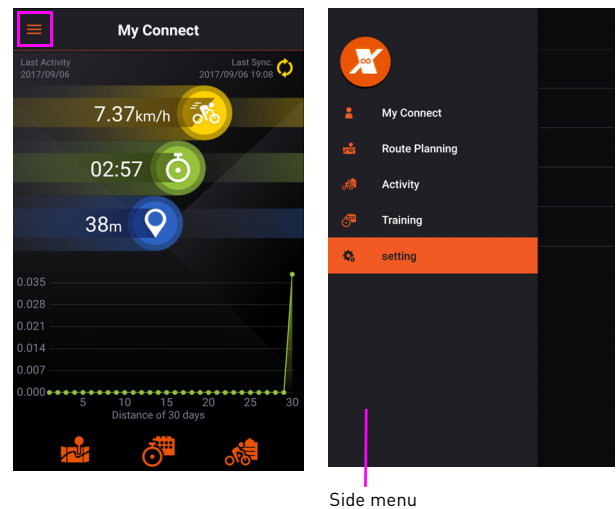

3. Go to **Settings > My Device**.
4. Tap icon at the bottom-right corner of the screen and select **X5 Evo**.
5. Follow the prompts to begin pairing.

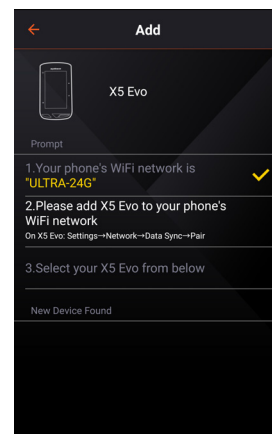

Before pairing, make sure the X5 Evo's Wi-Fi is connected to your smartphone's hotspot.

6. On X5 Evo, select **Settings > Network > Data Sync**. Then tap **PAIR** as prompted.

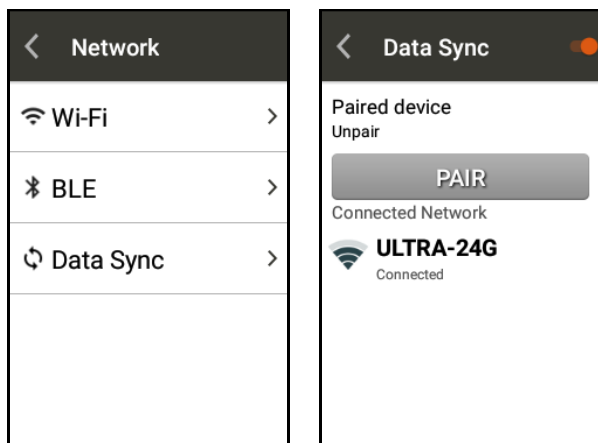

- On your smartphone, select **X5 Evo** from the **New Device Found** list.

Please turn **Download & Upload** switch to **ON** (default) for automatic data transmission.

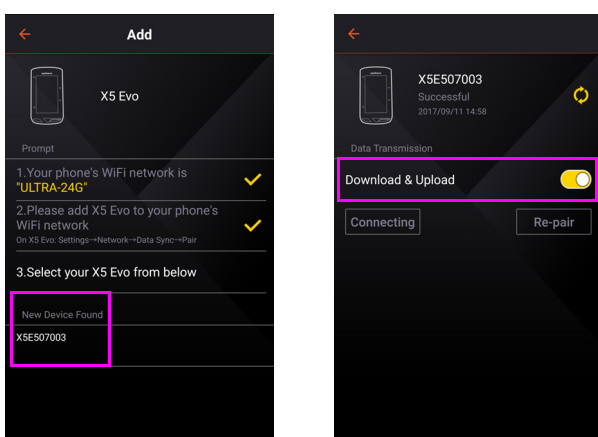

- Once successfully paired, the activity data will be automatically transferred from X5 Evo to smartphone.

- Unpair

On X5 Evo, select **Settings > Network > Data Sync**. Then tap **UNPAIR**.

NOTE

- You only need to pair your smartphone with X5 Evo once and it will automatically recognize X5 Evo each time.
- Tap  icon on **My Connect** screen to get the latest Sync update.

Route Planning

By using Route Planning function, you can manually create your own custom route (without SmartSign™) and send it to your X5 Evo.

- Route Planning screen:

- Go to Side menu and select **Route Planning** or tap  icon on **My Connect** screen.

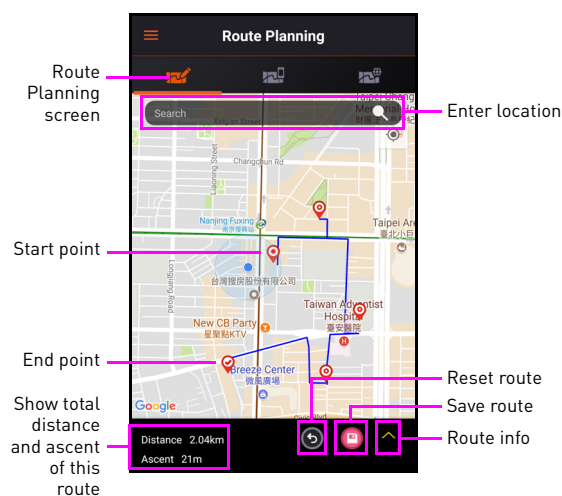

- On the **Route planning** screen, tap on the Search box to enter the name or address of the location where you'd like to create your route.

Or

Tap on the map directly to add one or more location(s).

- Once you choose the location(s), the route will be created.

Each location is marked as a pin and the route paths between the locations are highlighted with a blue line. You will see estimated distance and ascent at the bottom-left corner of the screen.

- Tap  icon at the bottom-right corner of the screen to save the route into **My Route**.

- My Route screen:

All custom routes which you created will be saved in **My Route** and ready for upload to X5 Evo.

- Go to the **My Route** screen and select one route from the list to view its details.

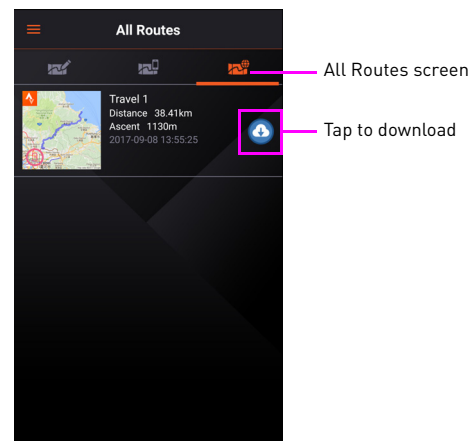
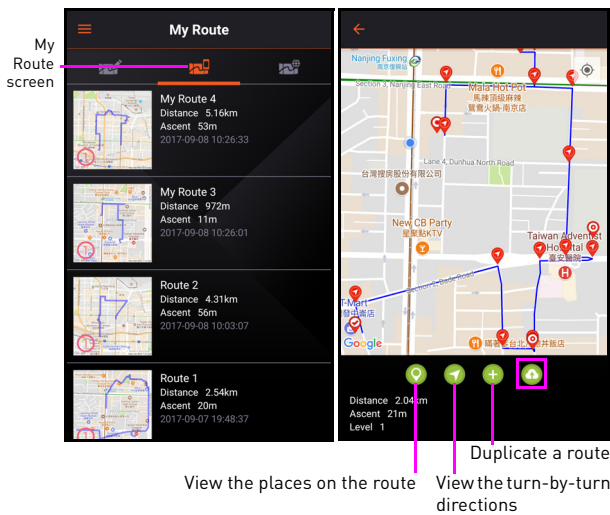

NOTE

- You can zoom in and out of the map by using the pinch and zoom gesture, or by double tapping the place you want to zoom.
- Long press a route to delete it.
- 2. Tap icon at the bottom-right corner of the screen to upload the selected route file to X5 Evo.
- All Routes screen:

You can find the route files which you created and saved in Xplova or Strava website on **All Routes** screen. Tap icon to download the selected route file to **My Route**.

For more information on how to create a route (with SmartSign™), please refer to their respective website for details.

NOTE

- In order to get routes sync with Xplova and Strava website, you must enable **Route download** feature in **Settings > Extended Function** (See [Extended Function](#)).

Activity

Once your smartphone and X5 Evo have been paired, all recorded activities from X5 Evo will be uploaded to Xplova Connect app on your smartphone and social platforms.

NOTE

- In order to get activities sync with Xplova and Strava website, you must enable **Activity upload** feature in **Settings > Extended Function** (See [Extended Function](#)).
- 1. Go to Side menu and select **Activity** or tap icon on **My Connect** screen.

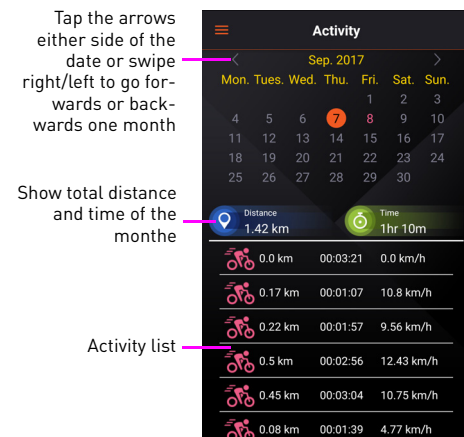

- 2. Tap on the date you'd like to view. From the activity list, tap one to view its cycling data in details.

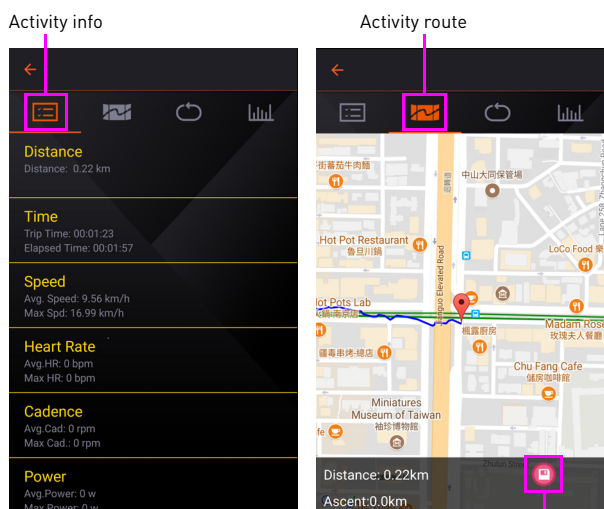

Tap to convert the activity to route and save into My Route

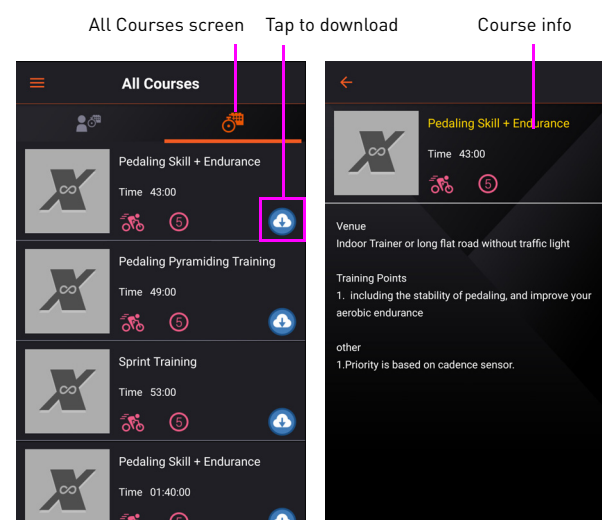
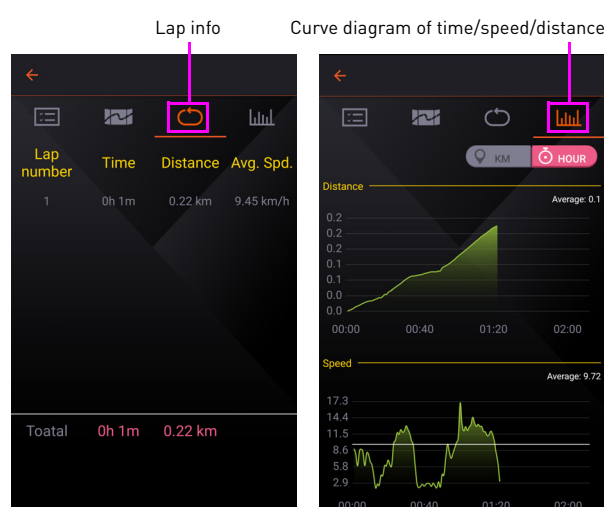

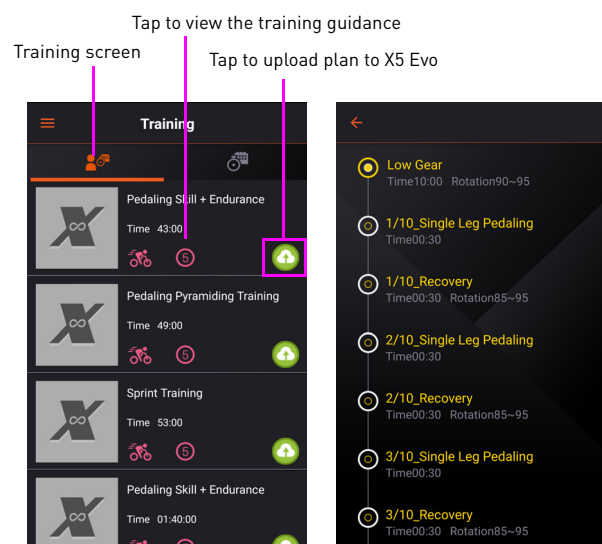

4. Go to **Training** screen, and tap  icon of the selected plan to send it to your X5 Evo for step-by-step guidance



■ Training

A training plan can be like a coach, it's a good way to make your training more effective and help you achieve your cycling goals. Choose from a comprehensive range of the plans to meet your individual needs, and then download and follow it directly on your X5 Evo.

1. Go to Side menu and select **Training** or tap  icon on **My Connect** screen.
2. On the **All Courses** screen, select one plan to view its description.
3. Tap  icon to download it to **Training**.

■ Settings

• Log

The **Log** gives you the full picture of your uploaded files to X5 Evo.

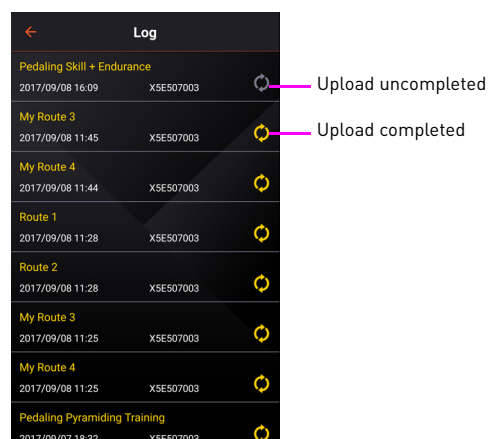

• **Extended Function**

Login Xplova or Strava website, enable **Activity upload** and **Route download** features to automatically sync your activities/routes between Xplova Connect app and websites.

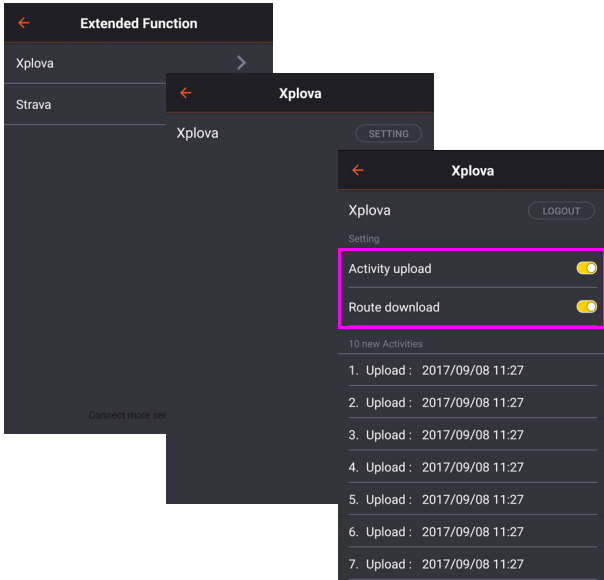

• **Instructions**

Display a brief set of instructions in which leading you into the initial impressions of the Xplova Connect app.

• **Privacy**

Provide a direct link to our Privacy Policy. Review our Privacy Policy for what information we collect and how it's used and secured.

Xplova Video

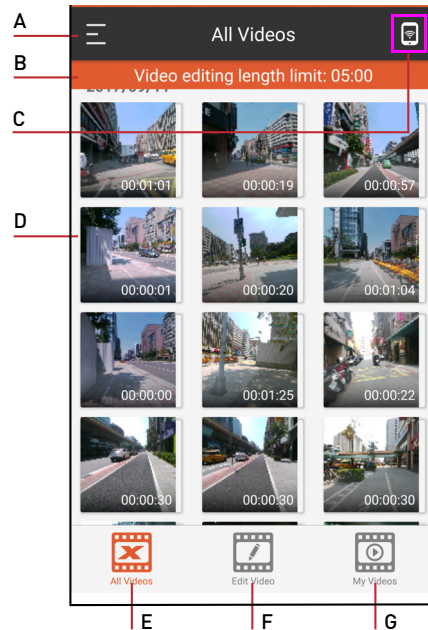

With the easy-to-use intuitive interface, you would be able to edit your videos in seconds and share them with the world easily via Xplova Video.





- A. Open Side menu
- B. Reminder of video editing length limit
- C. Tap to connect with X5 Evo
- D. Video thumbnails
- E. All Videos screen
- F. Edit Video screen
- G. My Video screen

■ **How to pair devices**

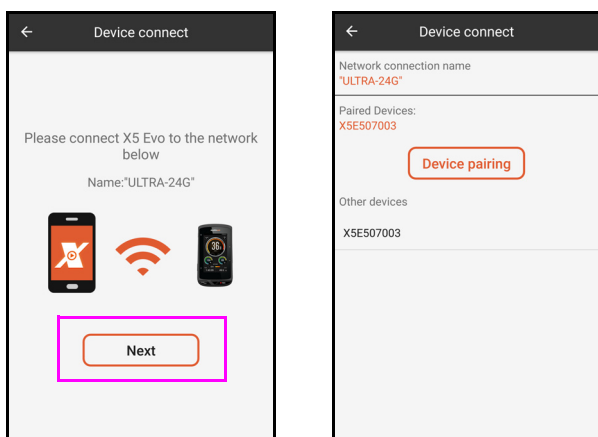

Follow the steps below to pair X5 Evo with your smartphone.

1. Launch the Xplova Video app on your smartphone.
 - tap  icon at the upper-right corner of the screen to connect X5 Evo; or
 - tap  icon at the upper-left corner of the screen; or swipe right from the left edge of the screen to pull open the Side menu. Select **Device connect**.

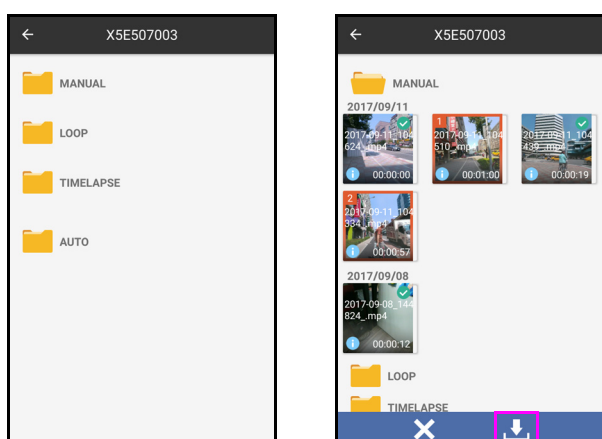

2. Connect X5 Evo's Wi-Fi to your smartphone's hotspot. Then tap **Next**.
3. Select X5 Evo from the **Other devices** list.
4. Once your smartphone and X5 Evo have been paired successfully, tap  icon again to access Video folders on X5 Evo.



5. Select a folder, long press the video clips you'd like to download and tap  icon to download. (The downloaded files are marked with  symbol.)
6. Video clips will be saved in thumbnail view in **All Videos** screen on Xplova Video app.

■ Play a video

Select a video clip from **All Videos** screen to play directly.

■ Crop a video

1. From **All Videos** screen, select a video clip you'd like to crop.
2. Locate the beginning and the ending points by dragging the arrow forward or backward on the timeline.

The video information displays in the lower part of the screen.

3. Tap the scissors icon  to crop the selected video.

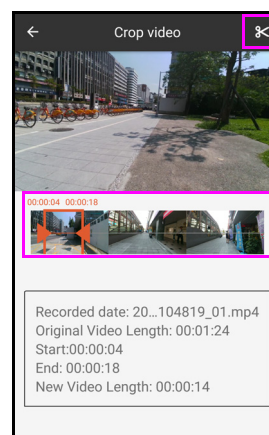

4. The cropped video will be saved in **All Videos** screen as a single clip.

NOTE

- You may find the symbols on the video clips which indicate:
 - Blue i: Video is with FIT data.
 - Red scissors: Video is cropped.
- The maximum length for a video editing is 5 minutes.

■ Edit a video

If you'd like to edit a single video clip (or multiple video clips into one), please follow the steps below:

1. From **All Videos** screen, long press a video clip (or multiple ones by long pressing one by one at once), then tap the pen icon .
2. On **Edit Video** screen, select overlay effects to apply activity stats onto video directly.

NOTE

- When you join multiple video clips into one, just add overlay effects to one of the video clips.
- 3. Once video editing is completed, Tap  icon at the upper-right corner of the screen to create a video.

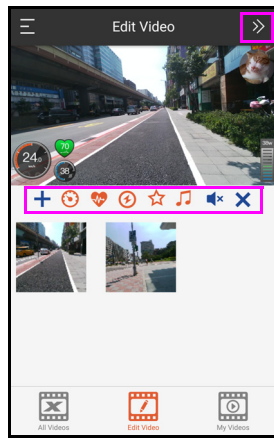
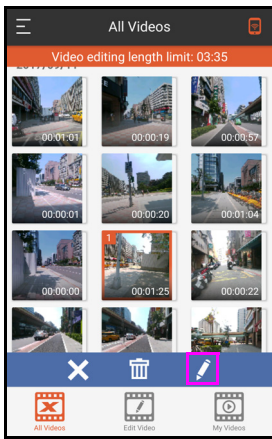

- Once video production is completed, a dialog box will pop up asking you to watch on **My Videos** screen. Select **Confirm** to watch; or select **Cancel** to discard.

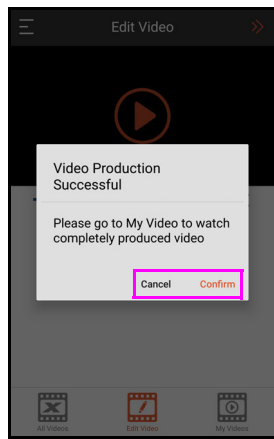
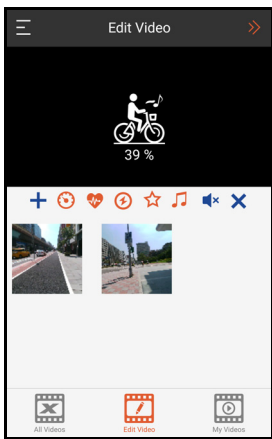

NOTE

- To deselect a video, tap **X** or long press it again.
- The edited videos are saved in the folder Movies/X5EVIDEO on your smartphone's internal memory.

Description of video overlay effects:

Symbol	Function
	Select multiple video clips from smartphone to combine with X5 Evo videos. (only 720p resolution is supported)
	Attach speed data.
	Add heart rate data.
	Add power data.
	Attach customized logo.

- Use default music.
- Remove original audio track.
- Delete all videos in the editing area.

Share a video

- Select the video you'd like to share in **My Videos** screen.
- Select the way you'd like to share, such as via Facebook or YouTube.

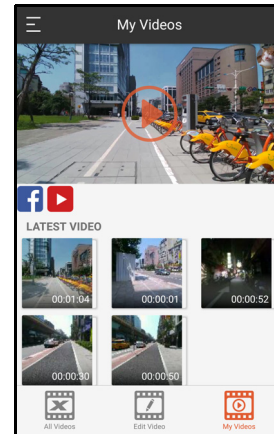

Delete a video

- Long press a video thumbnail to select it and tap the trash icon .
- A dialog box will pop up asking you to confirm the deletion.
- Select **Confirm** to delete; or select **Cancel** to discard.

Side menu settings

Tap icon at the upper-left corner of the screen or swipe right from the left edge of the screen to pull open the Side menu.

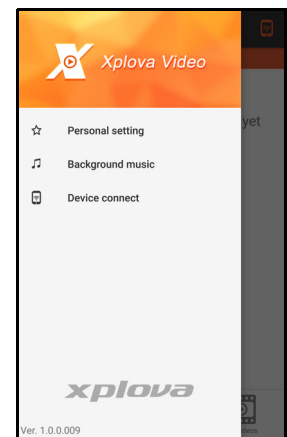
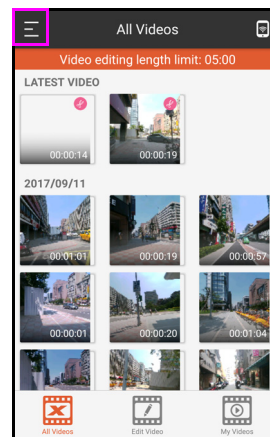

- Personal setting

With this function, it's simple to create your own logo through inserting a picture from your smartphone's Gallery and adding texts.

1. Select **Personal setting** from the Side menu.
2. Tap **Edit** > **+** to select a photo.
3. Tap text field to compose your own texts or slogans.
4. Tap **Done**.

Now, you can overlay your own unique logo onto videos.

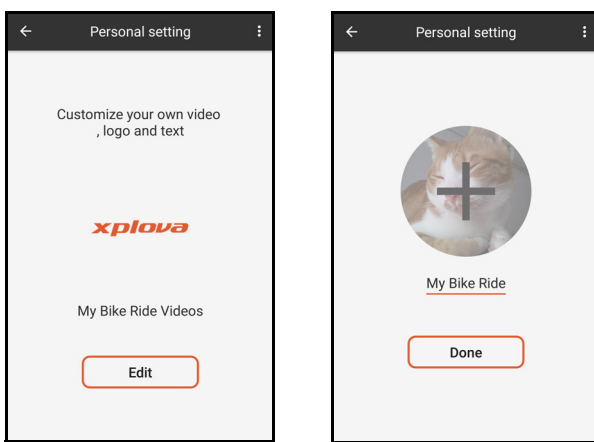

- Background music

Add a background music to videos to make your videos more attractive.

1. Select **Background music** from the Side menu.
2. Select the preferred one from the list.
3. Tap .

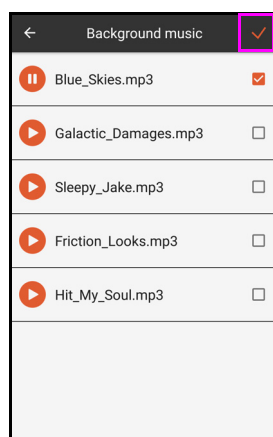

GENERAL SETTINGS

Tap on  icon on the Home screen to enter the **Settings** menu. Go through the menu and make necessary settings to enhance your cycling experiences.

NOTE

- Press [UP/DOWN] button to scroll vertically through the menu options and press [START/STOP] button to go deeper to the next menu level.

Profile

You can edit your personal information. Please make sure to enter the correct data since it may affect the analyses.

Go to **Settings > Profile**.

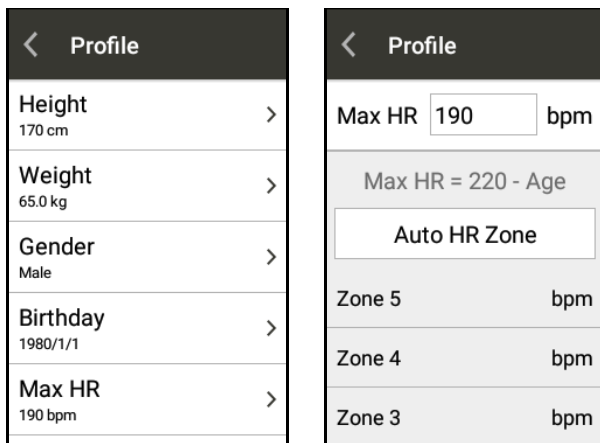

Bike mode

X5 Evo provides you 4 different bike modes that best suit various riding purposes. Please go to [page 11](#) for more information on Bike mode.

Bike

Adjust for wheel size and gear ratio changes. Please go to [page 12](#) for more information on Bike settings.

Device

Please go to:

- [Page 18](#) for more information on Alert Settings.

- [Page 18](#) for more information on Activity Settings.
- [Page 12](#) for more information on Altitude Calibration.

My Map

Please go to [page 19](#) for more information on My Map.

Record Settings

Please go to [page 23](#) for more information on Record Settings.

ANT+ sensors

Please go to [page 30](#) for more information on ANT+ sensors.

Network

Please go to [page 32](#) for more information on Network setting.

System

■ GPS

Please go to [page 12](#) for more information on GPS setting.

■ Display

You can adjust the theme, backlight time and backlight brightness.

Go to **Settings > System > Display**.

- **Theme:** Adjust the display color.

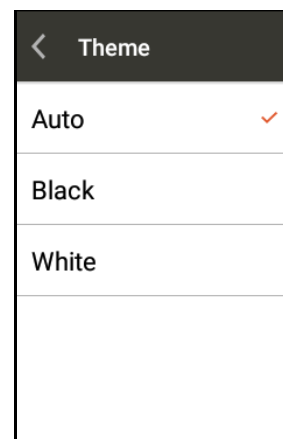

- **Backlight On:** You can adjust the backlight time to meet your need.



- **Brightness:** Adjust the backlight brightness.

Select **Auto-Brightness** or drag the slider to adjust the backlight brightness according to your preference.

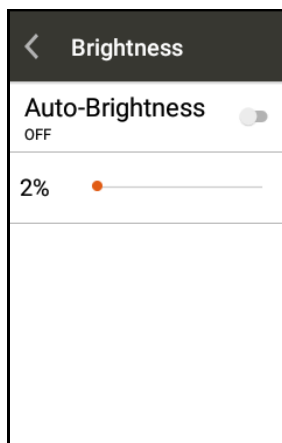

■ Hibernate

Automatically set your X5 Evo to hibernate after a specific period of time.

Go to **Settings > System > Hibernate**.

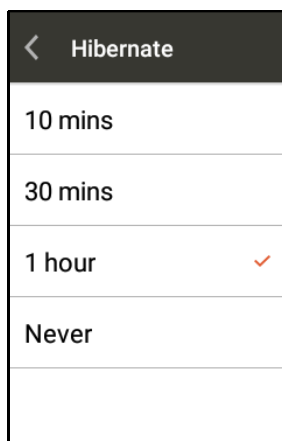

ⓘ NOTE

- This function will not take effect while the recording is in progress. The Hibernate mode is activated when you stop recording.

■ Sounds

Sounds are emitted when controlling and operating X5 Evo.

Go to **Settings > System > Sounds**.

- **Keyboard Clicks:** Whether to emit sound when pressing the physical buttons. You can set it to ON/OFF.
- **Touch Sounds:** Whether to emit sound when touching the screen. You can set it to ON/OFF.
- **Volume:** Drag the volume slider to adjust the volume level.

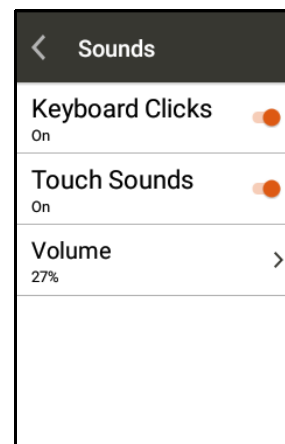

ⓘ NOTE

- This volume feature also controls the volume for the alerts and other sound effects.

■ Time

Go to **Settings > System > Time**.

Display the current time and configure the time zone. It is recommended to turn on **Set Automatically** to set the date and time based on your time zone.

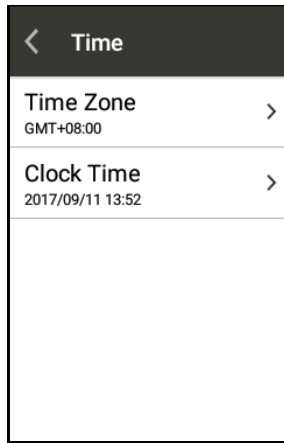

■ Units

Set either Metric or Statute for the distance, altitude, temperature and other units of measurement.

Go to **Settings > System > Units**.

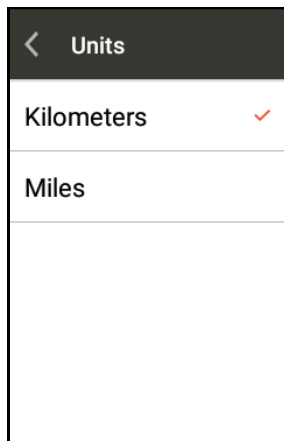

■ Language

You can set the display language.

Go to **Settings > System > Language**.



■ Clear User Data

You can delete the information saved on X5 Evo.

Go to **Settings > System > Clear User Data**.

- **Clear User Activities:** Clear the activities and videos saved on X5 Evo.
- **Restore Default Settings:** Restore all settings to the default values.
- **Factory Reset:** Reset all settings to the factory default.



ⓘ NOTE

- The deleted activities and videos cannot be restored. Please backup the information or upload the records to the Cloud platform.

■ About

Display the software version, model name, serial number, as well as updating your X5 Evo to the latest version.

Go to **Settings > System > About**.

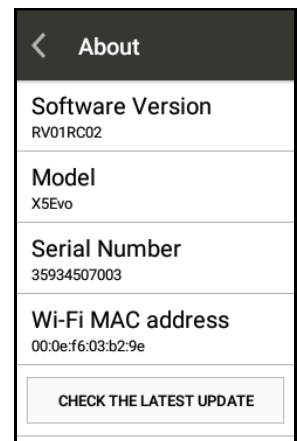
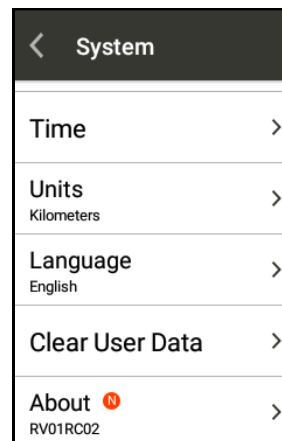

APPENDIX

Descriptions of customized data fields

Value Field	Description
Category: Navigation	
Direction	Current ride direction
Route Dist.	Load route and ride with total distance of the route being
Dist.to Dest.	Load route and ride with an estimated distance between current location and destination being
Time to Dest.	Load route and ride with the estimated time remaining from current location to destination being
Dist.to Next	Load route and ride with the distance between current location and next waypoint being
Time to Next	Load route and ride with the time remaining from current location to next waypoint being
Category: Altitude	
Grade	Current grade
Altitude	Current attitude
Max altitude	Max altitude in this record
Max Grade	Max grade in this record
Vert. speed	Speed of ascent or descent over time
Total Ascent	Accumulated total ascent altitude of this record information
Total Descent	Accumulated total descent altitude of this record information (represented in negative number)
Lap climb	Accumulated total ascent altitude of the current lap
Lap decline	Accumulated total descent altitude of the current lap
L-Lap climb	Accumulated total ascent altitude of the last lap
L-Lap decline	Accumulated total descent altitude of the last lap
Category: Power	
Power	Current output power
Power Zone	Current output power range (1~7), please confirm the represented value of range 1~7 from the "Power" of "Profile"
FTP %	FTP functional threshold power value
W per kg	Current output power in watts per kilogram
NP	Normalized Power

TSS	"Grade your training intensity and estimate days for recovery in order to arrange the next training. Recommendation of score recovery: <150: Normal training may be resumed on the next day 150-300: Normal training may be resumed on the third day 300-450: Fatigue feeling still exists for the third day training >450: Fatigue lasts for more than three days * Formula: $[(\text{second} * \text{normalized power} * \text{intensity factor}) / (\text{FTP} * 3600)] * 100$ "
kilojoules	Accumulated power - Joule of this record
Avg. Power	Average power of this record
3s Avg. Power	Average power output in the last 3 seconds
30s Avg. Power	Average power output in the last 30 seconds
3 mins Avg. Power	Average power output in the last 3 minutes
20 mins Avg. Power	Average power output in the last 20 minutes
IF	Intensity Factor
Max Power	Maximum power of this record
Lap Power	Average power of the current lap in this record
Lap Max Power	Maximum power of the current lap in this record
Lap NP	Normalized power of the current lap in this record
L-Lap Power	Average power of the last lap in this record
L.L Max Power	Maximum power of the last lap in this record
R Power	Right foot output power
R Power %	Percentage of right foot output power in total output power
L Power	Left foot output power
L Power %	Percentage of left foot output power in total output power
L-R Power %	Left foot output power: Right foot output power
30s Bal.Pwr.	Average output power in the last 30 seconds - Left foot output power: Right foot output power
3s Bal. Pwr.	Average output power in the last 3 seconds - Left foot output power: Right foot output power
Lap L-R Power	Single lap - Left foot output power: Right foot output power
L-R Avg Power	Average power of this record - Left foot output power: Right foot output power
Pedal Smooth	Ratio of average force and maximum force in pedaling cycle
Torque Effect	Torque effect = $(\text{positive power} + \text{negative power}) / \text{positive power} * 100\%$
Category: Time	
Elapsed Time	Timer time + Pause time = Elapsed time
Timer Time	Elapsed time - Pause time = Timer time

Avg. Lap Time	Average time of each lap (timer time / total laps)
Lap Time	Timer time of the current lap
Complete Laps	Number of laps completed in this record
L-Lap Time	Timer time of the last lap
Paused Time	Accumulated time in pause conditions
Category: Distance	
Distance	Accumulated total distance traveled of this record
Lap Dist.	Accumulated total distance of the current lap in this record
L-Lap Dist.	Accumulated total distance of the last lap in this record
Category: Calories	
Calories	Accumulated calories (Kcal) of this record
Calories %	Calories burn rate (Kcal/hr) per hour of this record
Category: Speed	
Speed	Current speed
Avg. Spd	Average speed of this record (distance / timer time)
Max Spd	Maximum speed of this record
Lap Spd	Average speed of the current lap (lap distance / lap time)
Lap Max Spd	Maximum speed of the current lap
L-Lap Spd	Average speed of the last lap (distance of the last lap / time of the last lap)
L.L Max Spd	Maximum speed of the last lap
Category: Cadence	
Cadence	Current number of cadence (rotation per minute, rpm)
Avg. Cad.	Average number of cadence of this record (accumulated number of cadence under the condition of cadence>0 / total time of cadence>0)
Max Cad.	Maximum number of cadence of this record
Lap Cad.	Average number of cadence of the current lap in this record
Lap Max Cad.	Maximum number of cadence of the current lap in this record
L-Lap Cad.	Average number of cadence of the last lap in this record
L.L Max Cad.	Maximum number of cadence of the last lap in this record
Category: Heart Rate	
Heart Rate	Current heart rate, unit is beat per minute (bpm)
HR Zone	Current heart rate range (1~5), please confirm the represented value of range 1~5 from the "Max HR" of "Profile"
Max HR	Maximum heart rate of this record
Avg.HR	Average heart rate of this record (accumulated number of heart rate under the condition of heart rate>0 / total time of heart rate>0)

Appendix

HR (%)	Current heart rate / preset maximum heart rate
Lap HR	Average heart rate of the current lap in this record
Lap HR %	Average heart rate of the current lap / preset maximum heart rate (input from the "Profile")
Lap Max HR	Maximum heart rate of the current lap in this record
L-Lap HR	Average heart rate of the last lap in this record
L-Lap HR%	Average heart rate of the last lap / preset maximum heart rate
L.L Max HR	Maximum heart rate of the last lap in this record
Category: Train	
Current Training	Name of training plan executed currently
Current Training Step	Name of training step executed currently
Category: General	
Date	Current date
Clock Time	Current time
Sunrise	Time of the sun rises above the horizon in current GPS positioning
Sunset	Time of the sun sets below the horizon in current GPS positioning
Temperature	Current temperature
Battery level	Battery level of X5 Evo currently
Longitude	Current GPS positioning latitude
Latitude	Current GPS positioning longitude
GPS Strength	Strength level of current GPS signal
Category: Shimano Di2	
Front Gear	Number of front gears
Rear Gear	Number of rear gears
Gear Combo	Combination of numbers of front and rear gears
Gear Ratio	Gear ratio = Number of front gears / Number of rear gears
Di2 power	Current power level of SHIMANO Di2

Specifications

Display	3-inch, Transflective type, with 240x400 pixels
Water Rating	IPX7 (Max. 1 m under water for 30 mins)
Video Camera/Spec.	120 degree wide-angle camera with HD 720P@30fps
Internet Connection	Wi-Fi; BLE
GPS	High sensitivity GPS/GLONASS dual system
Memory	512MRAM/8G flash
Auto/manual Video recording	3, 6, 9, 30 seconds videos, Support cycle video recording Support time-lapse photography
SIM card slot(s)/ 3G band(s)	None
Map	Supports OSM maps and 10,000+ routes for free download at Xplova.com
Size and Weigh	110 x 62 x 23 mm, 120g
Battery	Rechargeable Lithium battery/1500 mAh/ approximately 12 hours (Wi-Fi/Backlight off; GPS 3D-Fixed)
Input	5V Micro-USB
Built-in Sensors	Temperature, Barometric altimeter, Ambient light
Support ANT+	HRM Chest Belt, Speed Sensor, Cadence Sensor, Combo(speed&cadence) sensor XA-CS2, Power Meter
Package	Xplova X5 Evo, Extended Holder, Micro-USB Cable, Strap, Quick Start Guide, Warranty Card

***Note:** Equipped with IPX7 Waterproof function, X5 Evo can maintain its proper function in water less than 1 meter deep for up to 30 minutes. Be particularly to note that it is not waterproof without covered with the weather cap which connect to the Micro USB port. Please cover with the weather cap when you are riding a motorcycle in the rain. If you would like to charge your X5 Evo after riding in the rain, please turn off your X5 Evo first and make sure to let it completely dry before charging.

***Note:** This is under the condition of Laboratory Testing, turning off the backlight and Wi-Fi functions and under the GPS positioned condition shall not be treated as guarantee of real live situation. It is only for the reference of device's functions.

***Note:** Information is for reference only and is subject to change without notice. For the latest specification, please visit our official website.

Declaration of Conformity

We,

Acer Incorporated

8F, 88, Sec. 1, Xintai 5th Rd., Xizhi, New Taipei City 221, Taiwan

Contact Person: Mr. RU Jan, E-mail: ru.jan@acer.com

And,

Acer Italy s.r.l.

Via Lepetit, 40, 20020 Lainate (MI) Italy

Tel: +39-02-939-921 ,Fax: +39-02 9399-2913

www.acer.it

Product: Smart Video Cycling Computer

Trade Name: Xplova

Model Number: X5 Evo

We, Acer Incorporated, hereby declare under our sole responsibility that the product described above is in conformity with the relevant Union harmonization legislation: Directive 2014/53/EU on Radio Equipment, RoHS Directive 2011/65/EU. The following harmonized standards and/or other relevant standards have been applied:

EMCD Directive: 2014/30/EU

- EN 55032:2012/AC:2013 Class B
- EN 61000-3-2:2014 Class D
- EN 61000-3-3:2013
- EN 55024: 2010+A1:2015
- EN 301 489-1 V2.1.1
- EN 301 489-3 V1.6.1
- EN 301 489-17 V3.1.1

R&TTE Directive: 2014/53/EU

- EN 300 328 V2.1.1
- EN 301 893 V2.1.0

LVD Directive: 2014/35/EU

- EN 60950-1:2006/A11:2009/A1:2010/A12:2011/A2:2013
- EN 62209-2:2010
- EN 62311:2008
- EN 62479:2010
- EN 50566:2013

RoHS Directive: 2011/65/EU

- EN 50581:2012

This device contains the radio equipment and should operate with a minimum distance of 0 centimeters between the radiator and your body

Operation frequency and radio-frequency power are listed as below:

Bluetooth: 2402-2480MHz < 10 dBm

WLAN 2.4GHz: 2412MHz-2462MHz < 20 dBm

Year to begin affixing CE marking: 2017.



RU Jan / Sr. Manager
Acer Incorporated (Taipei, Taiwan)

6/29/2017
Date